



OWNER'S MANUAL

**⚠ Read this manual carefully
before operating this vehicle.**

**TRACER 9
GT**

MOTORCYCLE

MTT9GTM/MTT9GTMC (Tracer 9 GT)

LIT-11626-34-68

BAP-28199-10

Location of important labels	1
Safety information	2
Description	3
Special features	4
Instrument and control functions	5
For your safety – pre-operation checks	6
Operation and important riding points	7
Periodic maintenance and adjustment	8
Motorcycle care and storage	9
Specifications	10
Consumer information	11
Index	12



WARNING: Operating, servicing and maintaining a passenger vehicle or off-road vehicle can expose you to chemicals including engine exhaust, carbon monoxide, phthalates, and lead, which are known to the State of California to cause cancer and birth defects or other reproductive harm. To minimize exposure, avoid breathing exhaust, do not idle the engine except as necessary, service your vehicle in a well-ventilated area and wear gloves or wash your hands frequently when servicing your vehicle. For more information go to www.P65Warnings.ca.gov/passenger-vehicle

 **Read this manual carefully before operating the vehicle. This manual should stay with the vehicle if it is sold.**

Congratulations on your purchase of the Yamaha MTT9GTM / MTT9GTMC. This model is the result of Yamaha's vast experience in the production of fine sporting, touring, and pacesetting racing machines. It represents the high degree of craftsmanship and reliability that have made Yamaha a leader in these fields.

This manual will give you an understanding of the operation, inspection, and basic maintenance of this motorcycle. If you have any questions concerning the operation or maintenance of your motorcycle, please consult a Yamaha dealer.

The design and manufacture of this Yamaha motorcycle fully comply with the emissions standards for clean air applicable at the date of manufacture. Yamaha has met these standards without reducing the performance or economy of operation of the motorcycle. To maintain these high standards, it is important that you and your Yamaha dealer pay close attention to the recommended maintenance schedules and operating instructions contained within this manual.

Yamaha continually seeks advancements in product design and quality. Therefore, while this manual contains the most current product information available at the time of printing, there may be minor discrepancies between your motorcycle and this manual. If there is any question concerning this manual, please consult a Yamaha dealer.



WARNING

Please read this manual and the “YOU AND YOUR MOTORCYCLE: RIDING TIPS” booklet carefully before operating this motorcycle. Do not attempt to operate this motorcycle until you have attained adequate knowledge of its controls and operating features. Regular inspections and careful maintenance, along with good operating techniques, will help ensure that you safely enjoy the capabilities and reliability of this motorcycle.

Important manual information

EAU10134

Particularly important information is distinguished in this manual by the following notations:

	This is the safety alert symbol. It is used to alert you to potential personal injury hazards. Obey all safety messages that follow this symbol to avoid possible injury or death.
 WARNING	A WARNING indicates a hazardous situation which, if not avoided, could result in death or serious injury.
NOTICE	A NOTICE indicates special precautions that must be taken to avoid damage to the vehicle or other property.
TIP	A TIP provides key information to make procedures easier or clearer.

*Product and specifications are subject to change without notice.

EAU10194

**MTT9GTM / MTT9GTMC
OWNER'S MANUAL**
©2021 by Yamaha Motor Corporation, U.S.A.
1st edition, December 2020
All rights reserved.
Any reprinting or unauthorized use
without the written permission of
Yamaha Motor Corporation, U.S.A.
is expressly prohibited.
Printed in Japan.
P/N LIT-11626-34-68

Table of contents

Location of important labels	1-1	Fuel tank breather hose and overflow hose	5-25	Periodic maintenance chart for the emission control system	8-3
Safety information	2-1	Catalytic converter	5-26	General maintenance and lubrication chart	8-5
Description	3-1	Seats	5-26	Checking the spark plugs.....	8-9
Left view	3-1	Adjusting the rider seat height	5-27	Canister (for California)	8-10
Right view	3-2	Rider footrest position	5-30	Engine oil	8-10
Controls and instruments	3-3	Storage compartment.....	5-30	Why Yamalube.....	8-12
Special features	4-1	Windshield	5-30	Coolant	8-13
Cruise control system.....	4-1	Handlebar position	5-31	Air filter element.....	8-14
“D-MODE”	4-3	Adjusting the front and rear suspension	5-31	Checking the engine idling speed	8-14
“SUS-MODE”	4-4	Luggage strap holders	5-32	Valve clearance.....	8-15
“TCS-MODE”.....	4-5	Auxiliary DC jack.....	5-33	Tires	8-15
QSS	4-6	Auxiliary DC connector	5-33	Cast wheels	8-17
BC.....	4-7	Sidestand	5-34	Adjusting the clutch lever free play.....	8-18
Instrument and control functions ...	5-1	Ignition circuit cut-off system	5-34	Checking the brake lever free play.....	8-18
Main switch/steering lock.....	5-1	For your safety – pre-operation checks	6-1	Brake light switches	8-19
Handlebar switches.....	5-2	Operation and important riding points	7-1	Checking the front and rear brake pads	8-19
Indicator lights and warning lights.....	5-5	Engine break-in	7-1	Checking the brake fluid level	8-20
Displays	5-7	Starting the engine.....	7-2	Changing the brake fluid	8-21
Settings MENU	5-15	Shifting	7-3	Drive chain slack.....	8-22
Clutch lever	5-20	Parking	7-5	Cleaning and lubricating the drive chain.....	8-23
Shift pedal	5-20	Periodic maintenance and adjustment	8-1	Checking and lubricating the cables.....	8-24
Brake lever.....	5-21	Tool kit	8-2	Checking and lubricating the throttle grip.....	8-24
Brake pedal	5-21				
Brake control system (BC).....	5-21				
Fuel tank cap.....	5-23				
Fuel.....	5-23				

Table of contents

Checking and lubricating the brake and shift pedals8-25	Maintenance record..... 11-6
Checking and lubricating the brake and clutch levers.....8-25	YAMAHA MOTOR CORPORATION, U.S.A. 2020 AND LATER MODEL STREET & DUAL-PURPOSE MOTORCYCLE LIMITED WARRANTY..... 11-8
Checking and lubricating the centerstand and sidestand8-26	YAMAHA EXTENDED SERVICE (Y.E.S.)..... 11-10
Lubricating the swingarm pivots ...8-27	
Checking the front fork.....8-27	
Checking the steering8-28	
Checking the wheel bearings8-28	
Battery8-28	Index 12-1
Replacing the fuses.....8-30	
Vehicle lights8-32	
Replacing the license plate light bulb8-32	
Troubleshooting8-33	
Troubleshooting chart8-35	
Motorcycle care and storage9-1	
Matte color caution9-1	
Care9-1	
Storage.....9-3	
Specifications 10-1	
Consumer information11-1	
Identification numbers.....11-1	
Diagnostic connector11-3	
Vehicle data recording11-3	
Reporting safety defects11-4	
Motorcycle noise regulation11-5	

Location of important labels

EAU10385

1

Read and understand all of the labels on your vehicle. They contain important information for safe and proper operation of your vehicle. Never remove any labels from your vehicle. If a label becomes difficult to read or comes off, a replacement label is available from your Yamaha dealer.

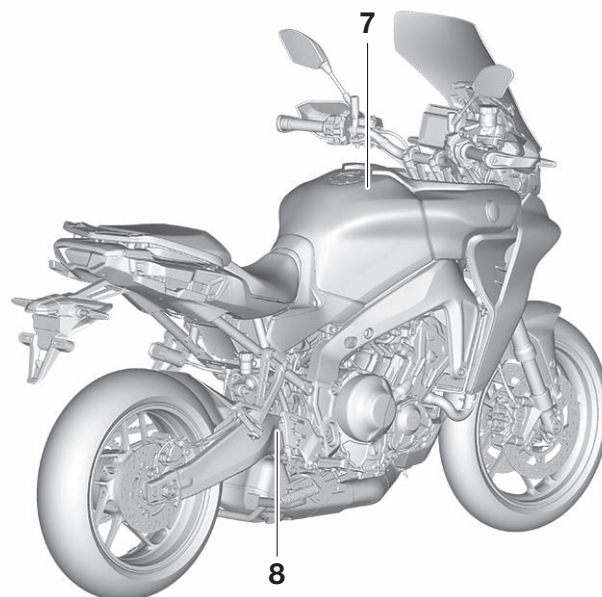
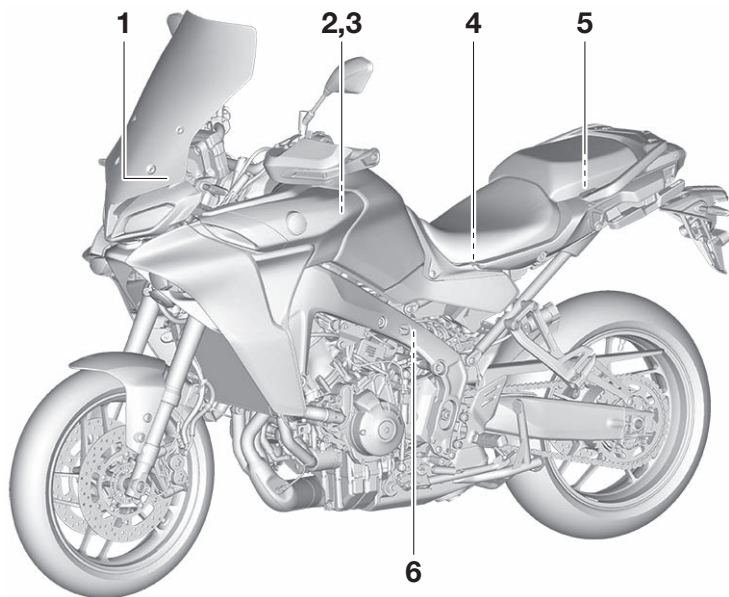

1

NOTICE

- Cleaning with alkaline or acid cleaner, gasoline or solvent will damage windshield.
- Use neutral detergent.

4B5-2815K-00

2 California only

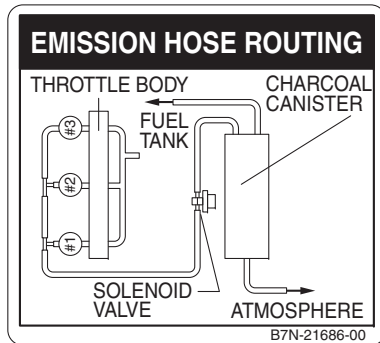

3 California only

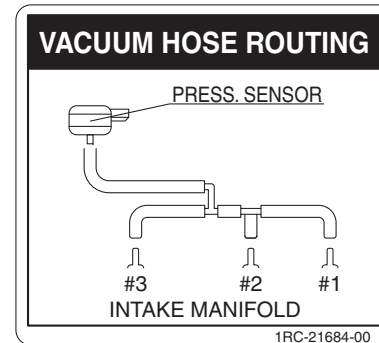

4

⚠ WARNING

Improper loading can cause loss of control.
Read owner's manual for proper loading.

3JJ-28446-A1

5

LOAD LIMIT

3 kg {7 lbs}

3TB-24877-A0

Location of important labels

1

6

⚠ WARNING

This unit contains high pressure nitrogen gas. Mishandling can cause explosion.

- Read owner's manual for instructions.
- Do not incinerate, puncture or open.

4AA-22259-90

7

⚠ WARNING

- BEFORE YOU OPERATE THIS VEHICLE, READ THE OWNER'S MANUAL AND ALL LABELS.
- ALWAYS WEAR AN APPROVED MOTOR CYCLE HELMET, eye protection, and protective clothing.

PREMIUM UNLEADED GASOLINE ONLY
91 Min. Pump Octane (R+M)/2

29P-2816R-01

8

TIRE INFORMATION

Cold tire normal pressure should be set as follows.

- Up to 90 kg (198 lbs) load

FRONT : 250 kPa, (2.50 kgf/cm²), 36 psi
REAR : 290 kPa, (2.90 kgf/cm²), 42 psi

- 90kg (198 lbs) ~ maximum load

FRONT : 250 kPa, (2.50 kgf/cm²), 36 psi
REAR : 290 kPa, (2.90 kgf/cm²), 42 psi

14B-21668-00

EAU1028C

Be a Responsible Owner

As the vehicle's owner, you are responsible for the safe and proper operation of your motorcycle.

Motorcycles are single-track vehicles. Their safe use and operation are dependent upon the use of proper riding techniques as well as the expertise of the operator. Every operator should know the following requirements before riding this motorcycle. He or she should:

- Obtain thorough instructions from a competent source on all aspects of motorcycle operation.
- Observe the warnings and maintenance requirements in this Owner's Manual.
- Obtain qualified training in safe and proper riding techniques.
- Obtain professional technical service as indicated in this Owner's Manual and/or when made necessary by mechanical conditions.

- Never operate a motorcycle without proper training or instruction. Take a training course. Beginners should receive training from a certified instructor. Contact an authorized motorcycle dealer to find out about the training courses nearest you.

Safe Riding

Perform the pre-operation checks each time you use the vehicle to make sure it is in safe operating condition. Failure to inspect or maintain the vehicle properly increases the possibility of an accident or equipment damage. See page 6-1 for a list of pre-operation checks.

- This motorcycle is designed to carry the operator and a passenger.
- The failure of motorists to detect and recognize motorcycles in traffic is the predominating cause of automobile/motorcycle accidents. Many accidents have been caused by an automobile driver who did not see the motorcycle. Making yourself conspicuous ap-

pears to be very effective in reducing the chance of this type of accident.

Therefore:

- Wear a brightly colored jacket.
- Use extra caution when you are approaching and passing through intersections, since intersections are the most likely places for motorcycle accidents to occur.
- Ride where other motorists can see you. Avoid riding in another motorist's blind spot.
- Never maintain a motorcycle without proper knowledge. Contact an authorized motorcycle dealer to inform you on basic motorcycle maintenance. Certain maintenance can only be carried out by certified staff.

Safety information

2

- Many accidents involve inexperienced operators. In fact, many operators who have been involved in accidents do not even have a current motorcycle license.
 - Make sure that you are qualified and that you only lend your motorcycle to other qualified operators.
 - Know your skills and limits. Staying within your limits may help you to avoid an accident.
 - We recommend that you practice riding your motorcycle where there is no traffic until you have become thoroughly familiar with the motorcycle and all of its controls.
- Many accidents have been caused by error of the motorcycle operator. A typical error made by the operator is veering wide on a turn due to excessive speed or undercornering (insufficient lean angle for the speed).
 - Always obey the speed limit and never travel faster than warranted by road and traffic conditions.
- Always signal before turning or changing lanes. Make sure that other motorists can see you.
- The posture of the operator and passenger is important for proper control.
 - The operator should keep both hands on the handlebar and both feet on the operator footrests during operation to maintain control of the motorcycle.
 - The passenger should always hold onto the operator, the seat strap or grab bar, if equipped, with both hands and keep both feet on the passenger footrests. Never carry a passenger unless he or she can firmly place both feet on the passenger footrests.
- Never ride under the influence of alcohol or other drugs.
- This motorcycle is designed for on-road use only. It is not suitable for off-road use.

Protective Apparel

The majority of fatalities from motorcycle accidents are the result of head injuries. The use of a safety helmet is the single most critical factor in the prevention or reduction of head injuries.

- Always wear an approved helmet.
- Wear a face shield or goggles. Wind in your unprotected eyes could contribute to an impairment of vision that could delay seeing a hazard.
- The use of a jacket, heavy boots, trousers, gloves, etc., is effective in preventing or reducing abrasions or lacerations.
- Never wear loose-fitting clothes, otherwise they could catch on the control levers, footrests, or wheels and cause injury or an accident.
- Always wear protective clothing that covers your legs, ankles, and feet. The engine or exhaust system become very hot during or after operation and can cause burns.
- A passenger should also observe the above precautions.

Avoid Carbon Monoxide Poisoning

All engine exhaust contains carbon monoxide, a deadly gas. Breathing carbon monoxide can cause headaches, dizziness, drowsiness, nausea, confusion, and eventually death.

Carbon Monoxide is a colorless, odorless, tasteless gas which may be present even if you do not see or smell any engine exhaust. Deadly levels of carbon monoxide can collect rapidly and you can quickly be overcome and unable to save yourself. Also, deadly levels of carbon monoxide can linger for hours or days in enclosed or poorly ventilated areas. If you experience any symptoms of carbon monoxide poisoning, leave the area immediately, get fresh air, and **SEEK MEDICAL TREATMENT**.

- Do not run engine indoors. Even if you try to ventilate engine exhaust with fans or open windows and doors, carbon monoxide can rapidly reach dangerous levels.
- Do not run engine in poorly ventilated or partially enclosed areas such as barns, garages, or carports.

- Do not run engine outdoors where engine exhaust can be drawn into a building through openings such as windows and doors.

Loading

Adding accessories or cargo to your motorcycle can adversely affect stability and handling if the weight distribution of the motorcycle is changed. To avoid the possibility of an accident, use extreme caution when adding cargo or accessories to your motorcycle. Use extra care when riding a motorcycle that has added cargo or accessories. Here, along with the information about accessories below, are some general guidelines to follow if loading cargo to your motorcycle:

The total weight of the operator, passenger, accessories and cargo must not exceed the maximum load limit.

Operation of an overloaded vehicle could cause an accident.

<p>Maximum load: 193 kg (425 lb)</p>

When loading within this weight limit, keep the following in mind:

- Cargo and accessory weight should be kept as low and close to the motorcycle as possible. Securely pack your heaviest items as close to the center of the vehicle as possible and make sure to distribute the weight as evenly as possible on both sides of the motorcycle to minimize imbalance or instability.
- Shifting weights can create a sudden imbalance. Make sure that accessories and cargo are securely attached to the motorcycle before riding. Check accessory mounts and cargo restraints frequently.
- Properly adjust the suspension for your load (suspension-adjustable models only), and check the condition and pressure of your tires.
- Never attach any large or heavy items to the handlebar, front fork, or front fender. These items, including such cargo as sleeping bags, duffel bags, or

Safety information

2

tents, can create unstable handling or a slow steering response.

- **This vehicle is not designed to pull a trailer or to be attached to a sidecar.**

Genuine Yamaha Accessories

Choosing accessories for your vehicle is an important decision. Genuine Yamaha accessories, which are available only from a Yamaha dealer, have been designed, tested, and approved by Yamaha for use on your vehicle.

Many companies with no connection to Yamaha manufacture parts and accessories or offer other modifications for Yamaha vehicles. Yamaha is not in a position to test the products that these aftermarket companies produce. Therefore, Yamaha can neither endorse nor recommend the use of accessories not sold by Yamaha or modifications not specifically recommended by Yamaha, even if sold and installed by a Yamaha dealer.

Aftermarket Parts, Accessories, and Modifications

While you may find aftermarket products similar in design and quality to genuine Yamaha accessories, recognize that some aftermarket accessories or modifications are not suitable because of potential safety hazards to you or others. Installing aftermarket products or having other modifications performed to your vehicle that change any of the vehicle's design or operation characteristics can put you and others at greater risk of serious injury or death. You are responsible for injuries related to changes in the vehicle.

Keep the following guidelines in mind, as well as those provided under "Loading" when mounting accessories.

- Never install accessories or carry cargo that would impair the performance of your motorcycle. Carefully inspect the accessory before using it to make sure that it does not in any way reduce ground clearance or cornering clearance, limit suspension travel,

steering travel or control operation, or obscure lights or reflectors.

- Accessories fitted to the handlebar or the front fork area can create instability due to improper weight distribution or aerodynamic changes. If accessories are added to the handlebar or front fork area, they must be as lightweight as possible and should be kept to a minimum.
- Bulky or large accessories may seriously affect the stability of the motorcycle due to aerodynamic effects. Wind may attempt to lift the motorcycle, or the motorcycle may become unstable in cross winds. These accessories may also cause instability when passing or being passed by large vehicles.
- Certain accessories can displace the operator from his or her normal riding position. This improper position limits the freedom of movement of the

operator and may limit control ability, therefore, such accessories are not recommended.

- Use caution when adding electrical accessories. If electrical accessories exceed the capacity of the motorcycle's electrical system, an electric failure could result, which could cause a dangerous loss of lights or engine power.

Aftermarket Tires and Rims

The tires and rims that came with your motorcycle were designed to match the performance capabilities and to provide the best combination of handling, braking, and comfort. Other tires, rims, sizes, and combinations may not be appropriate. See page 8-15 for tire specifications and for information on servicing and replacing your tires.

Transporting the Motorcycle

Be sure to observe following instructions before transporting the motorcycle in another vehicle.

- Remove all loose items from the motorcycle.
- Check that the fuel cock (if equipped) is in the off position and that there are no fuel leaks.
- Shift the transmission into gear (for models with a manual transmission).
- Secure the motorcycle with tie-downs or suitable straps that are attached to solid parts of the motorcycle, such as the frame or upper front fork triple clamp (and not, for example, to rubber-mounted handlebars or turn signals, or parts that could break). Choose the location for the straps carefully so the straps will not rub against painted surfaces during transport.
- The suspension should be compressed somewhat by the tie-downs, if possible, so that the motorcycle will not bounce excessively during transport.

Description

EAU10411

Left view

3

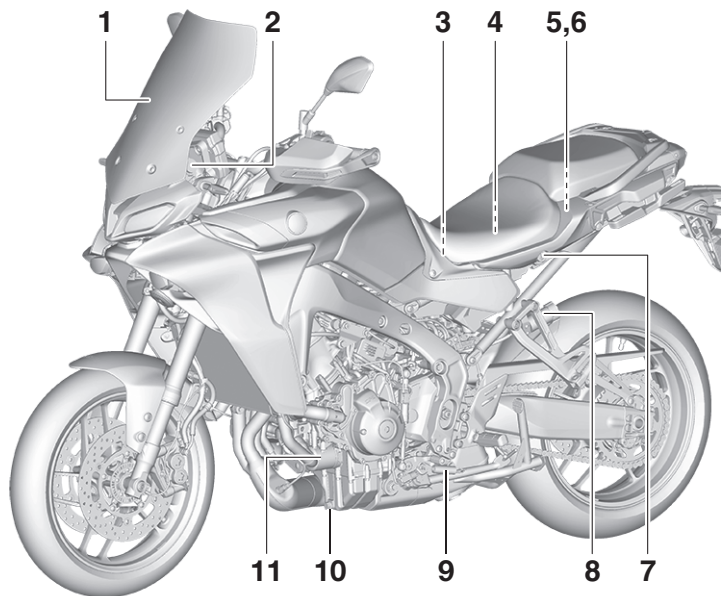

1. Windshield (page 5-30)
2. Auxiliary DC jack (page 5-33)
3. Battery (page 8-28)
4. Fuses (page 8-30)
5. Storage compartment (page 5-30)
6. Tool kit (page 8-2)
7. Seat lock (page 5-26)
8. Spring preload adjuster (page 5-31)

9. Shift pedal (page 5-20)
10. Engine oil drain bolt (page 8-10)
11. Engine oil filter cartridge (page 8-10)

Right view

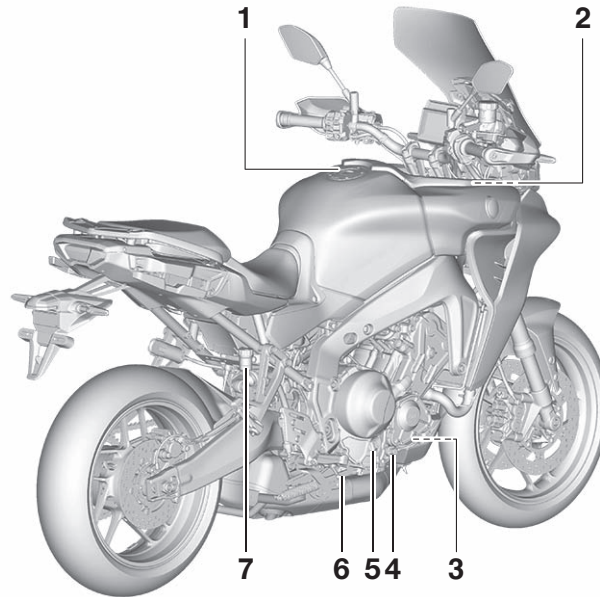

1. Fuel tank cap (page 5-23)
2. Spring preload adjuster (page 5-31)
3. Coolant reservoir (page 8-13)
4. Engine oil level check window (page 8-10)
5. Engine oil filler cap (page 8-10)
6. Brake pedal (page 5-21)
7. Rear brake fluid reservoir (page 8-20)

Controls and instruments

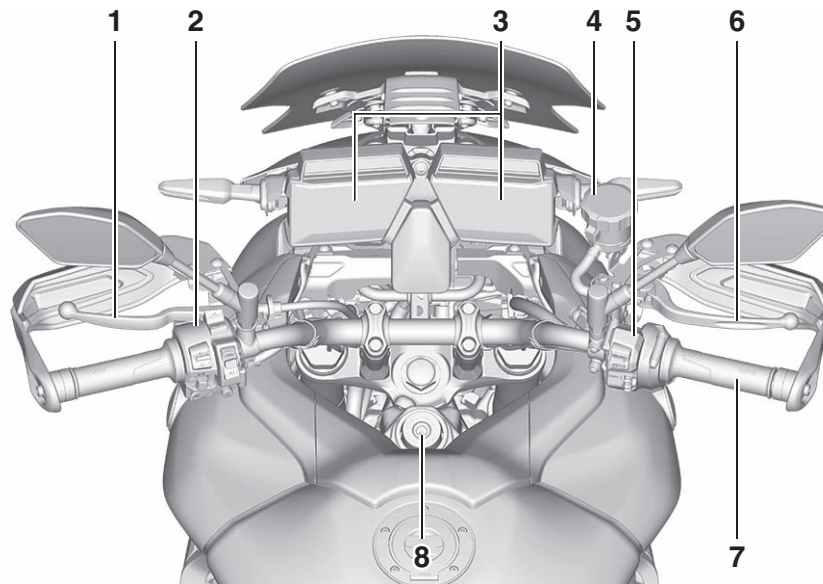
3

1. Clutch lever (page 5-20)
2. Left handlebar switches (page 5-2)
3. Instrument panel (page 5-5, 5-7)
4. Front brake fluid reservoir (page 8-20)
5. Right handlebar switches (page 5-2)
6. Brake lever (page 5-21)
7. Throttle grip
8. Main switch/steering lock (page 5-1)

Cruise control system

EAU92921

This model is equipped with a cruise control system designed to maintain a set cruising speed.

The cruise control system operates only when riding in 4th, 5th or 6th gear at speeds between about 50 km/h (31 mi/h) and 160 km/h (99 mi/h).

EWA21180

WARNING

- **Improper use of the cruise control system may result in loss of control, which could lead to an accident. Do not activate the cruise control system in heavy traffic, poor weather conditions, or among winding, slippery, hilly, rough or gravel roads.**
- **When traveling uphill or downhill, the cruise control system may not be able to maintain the set cruising speed.**
- **To prevent accidentally activating the cruise control system, turn it off when not in use. Make sure that the cruise control system indicator light “**

1. Cruise control system indicator light “

1. Cruise control setting switch “RES+”
2. Cruise control power switch “

Activating and setting the cruise control system

1. Push the cruise control power switch “

Adjusting the set cruising speed

While the cruise control system is operating, push the “RES+” side of the cruise control setting switch to increase the set cruising speed or the “SET-” side to decrease the set speed.

TIP

Pushing the setting switch once will change the speed in increments of approximately 2.0 km/h (2.0 mi/h). Holding the “RES+” or “SET-” side of the

Special features

cruise control setting switch down will increase or decrease the speed continuously until the switch is released.

You can also manually increase your traveling speed using the throttle. After you have accelerated, you can set a new cruising speed by pushing the “SET-” side of the setting switch. If you do not set a new cruising speed, when you return the throttle grip, the vehicle will decelerate to the previously set cruising speed.

TIP

The current cruise control speed setting can be viewed on the vehicle information displays. (See page 5-8.)

Deactivating the cruise control system

Perform one of the following operations to cancel the set cruising speed. The “SET” indicator light will go off.

- Turn the throttle grip past the closed position in the deceleration direction.

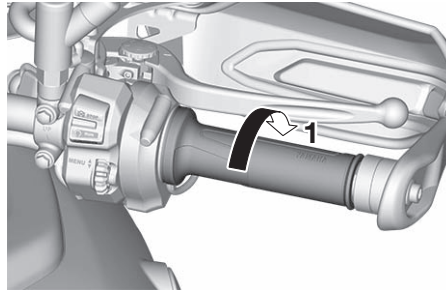

1. Deceleration direction

- Apply the front or rear brake.
- Disengage the clutch.
- Shift gears

Push the power switch to turn off the cruise control system. The “” indicator light and the “SET” indicator light will go off.

TIP

Traveling speed decreases as soon as the cruise control system is deactivated; unless the throttle grip is turned.

Using the resume function

Push the “RES+” side of the cruise control setting switch to reactivate the cruise control system. The traveling

speed will return to the previously set cruising speed. The “SET” indicator light will come on.

EWA16351

WARNING

It is dangerous to use the resume function when the previously set cruising speed is too high for current conditions.

TIP

Pushing the power switch while the system is operating will turn the system off completely and erase the previously set cruising speed. You will not be able to use the resume function until a new cruising speed has been set.

Automatic deactivation of the cruise control system

The cruise control system for this model is electronically controlled and is linked with the other control systems. The cruise control system will automatically become deactivated under the following conditions:

- The cruise control system is not able to maintain the set cruising speed.

“D-MODE”

“D-MODE” is an electronically controlled engine performance system.

WARNING

Do not change the drive mode while the vehicle is moving.

The “D-MODE” system consists of 4 different control maps which regulate engine response and output, thus providing you with a selection of modes to fit your preferences and the riding environment.



- D-MODE 1** - Sporty engine response
- D-MODE 2** - Moderate engine response
- D-MODE 3** - Mild engine response
- D-MODE 4** - Mild engine response and limits engine output

TIP

- The current “D-MODE” setting is shown in the MODE display. (See page 5-11.)
- The current “D-MODE” setting is saved when the vehicle is turned off.

- Wheel slip or wheel spin is detected. (If the traction control system has not been turned off, the traction control system will work.)
- The start/engine stop switch is set to the “” position.
- The engine stalls.
- The sidestand is lowered.

When traveling with a set cruising speed, if the cruise control system is deactivated under the above conditions, the “” indicator light will go off and the “**SET**” indicator light will flash for 4 seconds, and then go off.

When not traveling with a set cruising speed, if the start/engine stop switch is set to the “” position, the engine stalls, or the sidestand is lowered, then the “” indicator light will go off (the “**SET**” indicator light will not flash). If the cruise control system is automatically deactivated, please stop and confirm that your vehicle is in good operating condition.

Before using the cruise control system again, activate it using the power switch.

TIP

In some cases, the cruise control system may not be able to maintain the set cruising speed when the vehicle is traveling uphill or downhill.

- When the vehicle is traveling uphill, the actual traveling speed may become lower than the set cruising speed. If this occurs, accelerate to the desired traveling speed using the throttle.
- When the vehicle is traveling downhill, the actual traveling speed may become higher than the set cruising speed. If this occurs, the setting switch cannot be used to adjust the set cruising speed. To reduce the traveling speed, apply the brakes. When the brakes are applied, the cruise control system will become deactivated.

Special features

- The “D-MODE” is controlled by the MODE switches, see page 5-3 for more information.
-

4

“SUS-MODE”

EAU92770

“SUS-MODE” is an electronically controlled suspension damping system, called KYB Actimatic© Damper System (KADS), which automatically adjusts the suspension’s damping force to suit the riding situation.

EWA21170



WARNING

Do not change the suspension mode while the vehicle is moving.

The “SUS-MODE” system consists of 2 different control maps which regulate suspension damping force, thus providing you with a selection of modes to fit your preferences and the riding environment.

SUS-MODE A-1 - Sport setting with increased damping force, suitable for smoother road conditions

SUS-MODE A-2 - Comfort setting with softer damping force, suitable for rougher road conditions

TIP

- The current “SUS-MODE” setting is shown in the MODE display. (See page 5-11.)

- The current “SUS-MODE” setting is saved when the vehicle is turned off.
 - The “SUS-MODE” is controlled by the MODE switches, see page 5-3 for more information.
-

“TCS-MODE”

EAU92650

This model is equipped with adjustable traction, slide, and lift control systems (TCS, SCS and LIF). These are grouped together into “TCS-MODE”. “TCS-MODE” has 4 settings:

MODE	TCS	SCS	LIF
TCS-MODE 1	1	1	1
TCS-MODE 2	2	2	2
TCS-MODE M	1, 2, 3	OFF, 1, 2, 3	OFF, 1, 2, 3
TCS-MODE OFF	OFF	OFF	OFF

“TCS-MODE M” is customizable in the settings MENU, see page 5-16.

TCS

The traction control system helps maintain traction when accelerating. If sensors detect that the rear wheel is starting to slip (uncontrolled spinning), the traction control system assists by regulating engine power as needed until traction is restored. The stability control indicator light “SC” flashes to let the rider know that traction control has engaged.

This traction control system automatically adjusts according to the vehicle’s lean angle. To maximize acceleration, when the vehicle is upright a lesser amount of traction control is applied. When cornering, a greater amount of traction control is applied.



TIP

- The traction control system may engage when the vehicle travels over a bump.
- You may notice slight changes in engine and exhaust sounds when the traction control or other systems engage.

- The traction control system can only be turned off by setting “TCS-MODE” to “OFF”, using the MODE switches. See page 5-3 for more information on “TCS-MODE”.
- When “TCS-MODE” has been set to “OFF”, the TCS, SCS and LIF systems are all turned off together.

EWA15433

WARNING

The traction control system is not a substitute for riding appropriately for the conditions. Traction control cannot prevent loss of traction due to excessive speed when entering turns, when accelerating hard at a sharp lean angle, or while braking, and cannot prevent front wheel slipping. As with any vehicle, approach surfaces that may be slippery with caution and avoid especially slippery surfaces.

When the vehicle power is on, the traction control system automatically turns on. The traction control system can be

Special features

EAU91340

turned on or off manually only when the key is in the “ON” position and the motorcycle is stopped.

TIP

Set “TCS-MODE” to “OFF” to help free the rear wheel if the motorcycle gets stuck in mud, sand, or other soft surfaces.

ECA16801

NOTICE

Use only the specified tires. (See page 8-15.) Using different sized tires will prevent the traction control system from controlling tire rotation accurately.

SCS

The slide control system regulates engine power output when a sideward slide is detected in the rear wheel. It adjusts power output based on data from the IMU (Inertial Measurement Unit). This system supports the TCS to contribute to a smoother ride.





LIF

The lift control system reduces the rate at which the front wheel rises during extreme acceleration, such as during starts or out-of-corner exits. When front-wheel lift is detected, engine power is regulated to slow front-wheel lift while still providing good acceleration.

QSS

The quick shift system allows for clutch lever-less, electronically-assisted shifting. When the sensor on the shift rod detects the appropriate motion in the shift pedal, engine power output is momentarily adjusted to allow for the gear change to occur.

QSS does not operate when the clutch lever is pulled, therefore normal shifting can be done even when QSS is set to on. Check the QS indicator for current status and usability information.

QSS usability	Indicator
Upshifting OK	
Downshifting OK	
QSS cannot be used	
QSS turned off	

Upshifting conditions

- Vehicle speed of at least 20 km/h (12 mi/h)
- Engine speed of at least 2200 r/min
- Accelerating (open throttle)

Downshifting conditions

- Vehicle speed of at least 20 km/h (12 mi/h)
- Engine speed of at least 2000 r/min
- Engine speed sufficiently away from red zone
- Decelerating and throttle fully-closed

TIP

- QS ▲ and QS ▼ can be individually set.
- Shifting into or out of neutral must be done using the clutch lever.

BC

EAU91350

The brake control system regulates hydraulic brake pressure for the front and rear wheels when the brakes are applied and wheel lock is detected. This system has two settings.

BC1 is standard ABS, which adjusts brake pressure based on vehicle speed and wheel speed data. BC1 is designed to engage and maximize braking when the vehicle is upright.

BC2 uses additional data from the IMU to regulate applied brake power when cornering to suppress lateral wheel slip.

BC1/BC2



BC2



BC2



ABS

⚠ WARNING

EWA20891

The brake control system is not a substitute for the use of proper riding and braking techniques. The brake control system cannot prevent all loss of traction due to over-braking from excessive speed, or lateral wheel slip when braking on slippery surfaces.

Instrument and control functions

Main switch/steering lock

EAU10462

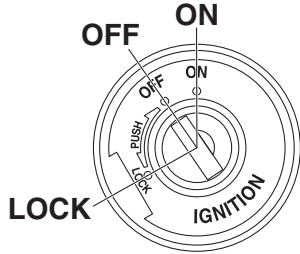

The main switch/steering lock controls the ignition and lighting systems, and is used to lock the steering. The various positions are described below.

ON

EAU84031

All electrical circuits are supplied with power and the vehicle lights are turned on. The engine can be started. The key cannot be removed.

TIP

- The headlight(s) will turn on when the engine is started.
- To prevent battery drain, do not leave the key in the on position without the engine running.

OFF

EAU10662

All electrical systems are off. The key can be removed.



WARNING

EWA10062

Never turn the key to “OFF” or “LOCK” while the vehicle is moving. Otherwise the electrical systems will be switched off, which may result in loss of control or an accident.

LOCK

EAU73800

The steering is locked and all electrical systems are off. The key can be removed.

To lock the steering

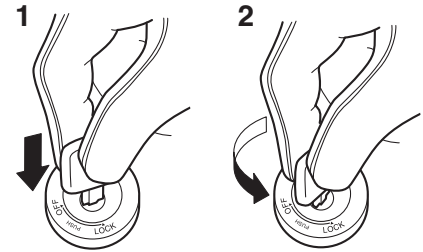

1. Push.
2. Turn.

1. Turn the handlebars all the way to the left.
2. With the key in the “OFF” position, push the key in and turn it to “LOCK”.
3. Remove the key.

TIP

If the steering will not lock, try turning the handlebars back to the right slightly.

To unlock the steering

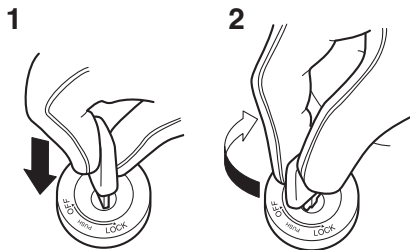

1. Push.
2. Turn.

Push the key in and turn it to “OFF”.

Handlebar switches

EAU66055

Left

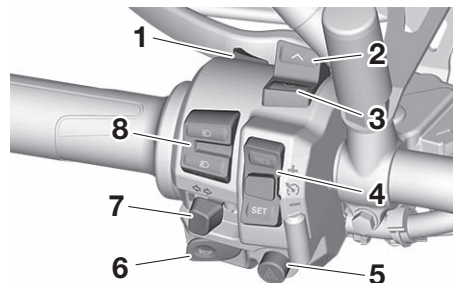

1. “MODE” switch
2. MODE up switch
3. MODE down switch
4. Cruise control switches
5. Hazard switch “ \triangle ”
6. Horn switch “ 📢 ”
7. Turn signal switch “ \leftarrow/\rightarrow ”
8. Dimmer/Pass switch “ \equiv/PASS ”

Right

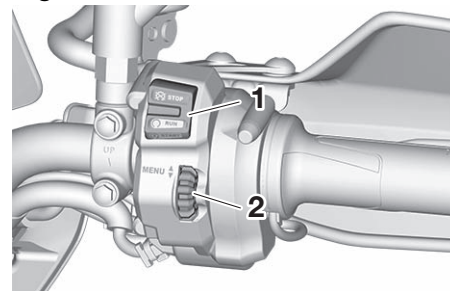

1. Stop/Run/Start switch “ $\text{⊗}/\text{○}/\text{⊗}$ ”
2. Wheel switch “MENU \blacklozenge ”

Dimmer/Pass switch “ \equiv/PASS ”

EAU91630

Set this switch to “ \equiv ” for the high beam and to “ PASS ” for the low beam. While the headlight is set on low beam, push the switch down towards “PASS” to flash the high beam and to mark the start of each lap when using the lap timer.

Instrument and control functions

5

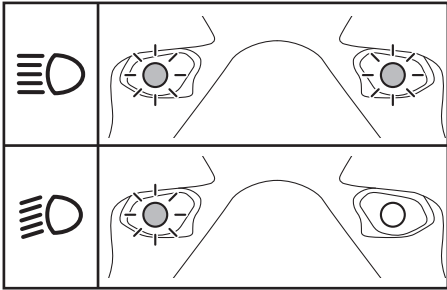

EAU66040

Turn signal switch “◁/▷”

To signal a right-hand turn, push this switch to “▷”. To signal a left-hand turn, push this switch to “◁”. When released, the switch returns to the center position. To cancel the turn signal lights, push the switch in after it has returned to the center position.

EAU66030

Horn switch “🔊”

Press this switch to sound the horn.

Stop/Run/Start switch “⊗/○/⊕”

EAU66061

To crank the engine with the starter, set this switch to “○”, and then push the switch down towards “⊕”. See page 7-2 for starting instructions prior to starting the engine.

Set this switch to “⊗” to stop the engine in case of an emergency, such as when the vehicle overturns or when the throttle cable is stuck.

Hazard switch “⚠️”

EAU91670

Use this switch to turn on the hazard lights (simultaneous flashing of all turn signal lights). The hazard lights are used in case of an emergency or to warn other drivers when your vehicle is stopped where it might be a traffic hazard.

The hazard lights can be turned on or off only when the key is in the “ON” position. You can turn the main switch to the “OFF” or “LOCK” position, and the hazard lights will continue to flash. To turn off the hazard lights, turn the main switch to the “ON” position and operate the hazard switch again.

ECA10062

NOTICE

Do not use the hazard lights for an extended length of time with the engine not running, otherwise the battery may discharge.

EAU73952

Cruise control switches

See page 4-1 for an explanation of the cruise control system.

EAU92660

MODE switches

Use the MODE switches to change the “D-MODE”, “SUS-MODE” and “TCS-MODE” located on the left side of the main display.

There are three mode controls:

MODE up switch - push this switch to change the selected mode setting upward.

“MODE” switch - push this switch to rotate counterclockwise between “D-MODE”, “SUS-MODE” and “TCS-MODE”.

MODE down switch - push this switch to change the selected mode setting downward.

EAU92670

TIP

- When in “D-MODE 1”, pressing the MODE up switch will cycle to “D-MODE 4”. When in “D-MODE 4”, pressing the MODE down switch will not cycle to “D-MODE 1”.
- The “TCS-MODE” can only be turned off from the main display. Select “TCS-MODE” with the “MODE” switch, then push and hold the MODE up switch until “OFF” is displayed.
- To turn the traction control system back on, use the MODE down switch.
- When “TCS-MODE” has been set to “OFF”, the TCS, SCS and LIF systems are all turned off together.
- See page 5-11 for more information on the MODE display.
- See page 4-3 for more information on “D-MODE”.
- See page 4-4 for more information on “SUS-MODE”.
- See page 4-5 for more information on “TCS-MODE”.

Wheel switch “MENU◆”

When the wheel switch is operated, a cursor will appear around the previously selected item on the main display or the sub-display.

The wheel switch controls:

- Vehicle information displays
- Settings MENU
- Grip warmer function (if equipped)
- Seat heater function (if equipped)

Operate the wheel switch as follows:

Rotate up - rotate the wheel upward to scroll up or increase a setting value.

Rotate down - rotate the wheel downward to scroll down or decrease a setting value.

Push inward - press the wheel switch in towards the handlebar to select items indicated by the cursor and confirm settings changes. Press and hold the switch inward to reset selected items.

TIP

- If the wheel switch is not operated for a certain period of time, the cursor will disappear.

- See page 5-7 for more information on the main display and sub-display and their functions.
- See page 5-15 for more information on the MENU screen and how to make settings changes.

Instrument and control functions

Indicator lights and warning lights

EAU4939P

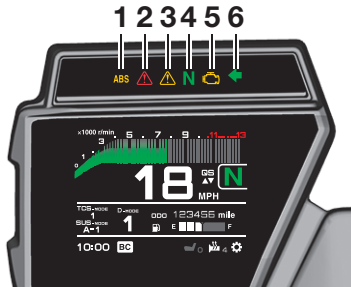

1. ABS warning light “ABS”
2. Oil pressure and Coolant temperature warning light “”
3. Auxiliary system warning light “”
4. Neutral indicator light “N”
5. Engine trouble warning light “”
6. Left turn signal indicator light “”

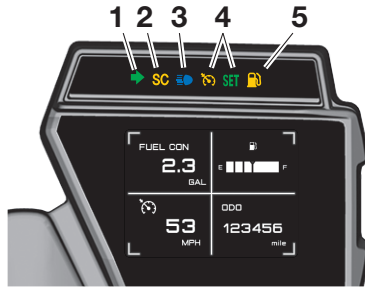

1. Right turn signal indicator light “”
2. Stability control indicator light “SC”
3. High beam indicator light “”
4. Cruise control indicator lights “”/“SET”
5. Fuel level warning light “”

Turn signal indicator lights “” and “”

EAU88680

Each indicator light will flash when its corresponding turn signal lights are flashing.

Neutral indicator light “N”

EAU91820

This indicator light comes on when the transmission is in the neutral position.

High beam indicator light “”

EAU88690

This indicator light comes on when the high beam of the headlight is switched on.

Fuel level warning light “”

EAU92680

This warning light comes on when the fuel level drops below approximately 3.0 L (0.79 US gal, 0.66 Imp.gal). When this occurs, refuel as soon as possible. The electrical circuit of the warning light can be checked by turning the vehicle on. The warning light should come on for a few seconds, and then go off.

TIP

If the warning light does not come on at all, remains on after refueling, or if the warning light flashes repeatedly, have a Yamaha dealer check the vehicle.

Cruise control indicator lights “”/“SET”

EAU92690

These indicator lights come on when the cruise control system is activated. (See page 4-1.)

TIP

When the vehicle is turned on, these lights should come on for a few seconds and then go off. Otherwise, have a Yamaha dealer check the vehicle.

Engine trouble warning light ”

EAU88920

This warning light comes on if a problem is detected in the engine or other vehicle control system. If this occurs, have a Yamaha dealer check the on-board diagnostic system.

TIP

When the vehicle is turned on, this light should come on for a few seconds and then go off. Otherwise, have a Yamaha dealer check vehicle.

ABS warning light ”

EAU92910

In normal operation, the ABS warning light comes on when the vehicle is turned on, and goes off after traveling at a speed of 5 km/h (3 mi/h) or higher.

TIP

If the warning light does not work as described above, or if the warning light comes on while riding, the ABS may not work correctly. Have a Yamaha dealer check the vehicle as soon as possible.

WARNING

EWA21120

If the ABS warning light does not turn off after reaching 5 km/h (3 mi/h), or if the warning light comes on while riding:

- Use extra caution to avoid possible wheel lock during emergency braking.
- Have a Yamaha dealer check the vehicle as soon as possible.

Stability control indicator light ”

EAU92720

This indicator light flashes when the TCS, SCS, or LIF systems engage while riding. When “TCS-MODE” is set to “OFF”, the indicator will come on.

TIP

When the vehicle is turned on, this light should come on for a few seconds and then go off. If the light does not come on, or if the light remains on, have a Yamaha dealer check the vehicle.

NOTICE

ECA27221

When turning the main switch on, avoid any movement or vibration of the vehicle as it may interfere with the initialization of the IMU. If this occurs, the TCS system will not operate and the “TCS-MODE” display will read “OFF” until the IMU can initialize.

Oil pressure and Coolant temperature warning light ”

EAU92751

This warning light comes on if the engine oil pressure is low or if the coolant temperature is high. If this occurs, stop the engine immediately.

TIP

- When the vehicle is first turned on, this light should come on until the engine is started.

Instrument and control functions

- If a malfunction is detected, this light will come on and the oil pressure icon will flash.

ECA22441

NOTICE

If the oil pressure and coolant warning light does not go off after starting the engine or if it comes on while the engine is running, stop the vehicle and engine immediately.

- If the engine is overheating, the coolant temperature warning icon will come on. Let the engine cool. Check the coolant level (see page 8-36).
- If the engine oil pressure is low, the oil pressure warning icon will come on. Check the oil level (see page 8-10).
- If the warning light remains on after letting the engine cool and confirming the proper oil level, have a Yamaha dealer check the vehicle. Do not continue to operate the vehicle!

Auxiliary system warning light “”

EAU92731

This warning light comes on if a problem is detected in a non-engine-related system.

TIP

When the vehicle is turned on, this light should come on for a few seconds and then go off. Otherwise, have a Yamaha dealer check the vehicle.

Displays

EAU92951

This vehicle is equipped with two display screens: a main display and a sub-display

The following items can be found on the displays:

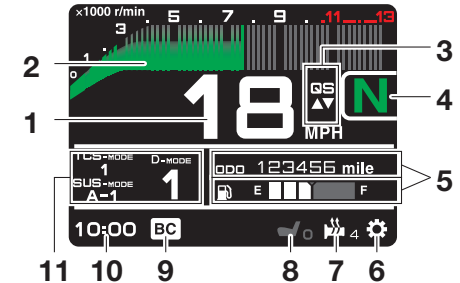

1. Speedometer
2. Tachometer
3. Quick shift indicator “QS”
4. Transmission gear display
5. Vehicle information displays
6. Settings MENU icon “”
7. Grip warmer indicator
8. Seat heater indicator (if equipped)
9. Brake control icon “BC”
10. Clock
11. MODE display

Instrument and control functions

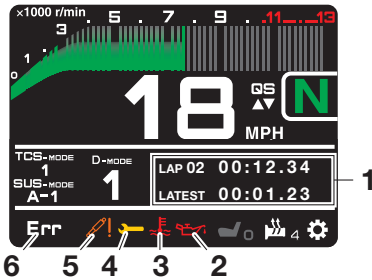

1. Lap timer
2. Oil pressure warning “”
3. Coolant temperature warning “”
4. Auxiliary system warning “”
5. SCU trouble warning “”
6. Error mode warning “Err” (replaces clock when activated)

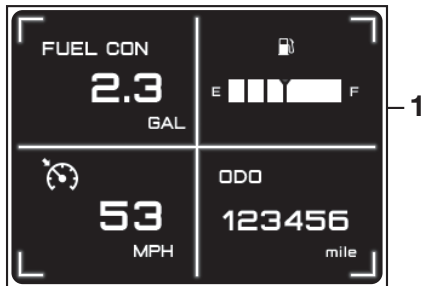

1. Vehicle information displays

TIP

- This model uses thin-film-transistor liquid-crystal displays (TFT LCD) for good contrast and readability in various lighting conditions. However, due to the nature of this technology, it is normal for a small number of pixels to be inactive.
- The display units can be switched between kilometers/miles and Celsius/Fahrenheit. See “Unit” on page 5-18.

WARNING

Stop the vehicle before making any setting changes. Changing settings while riding can distract the operator and increase the risk of an accident.

Speedometer

The speedometer shows the vehicle’s traveling speed.

Tachometer

The tachometer shows the engine speed, as measured by the rotational velocity of the crankshaft, in revolutions per minute (r/min).

ECA10032

NOTICE

Do not operate the engine in the tachometer red zone.

Red zone: 10600 r/min and above

5

Vehicle information displays

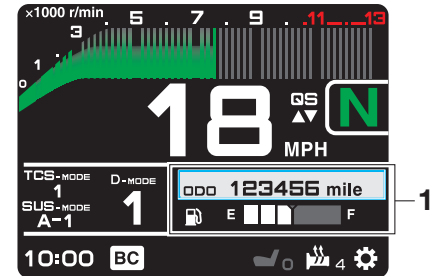

1. Vehicle information displays

Instrument and control functions

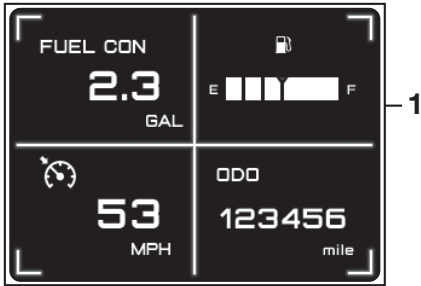

1. Vehicle information displays

The six vehicle information displays can be individually set to show the following items:

- ODO: odometer
- F-TRIP: fuel reserve tripmeter (main display (upper) only)
- TRIP1: tripmeter
- TRIP2: tripmeter
- F.AVE: average fuel economy
- F.CRNT: instantaneous fuel economy
- A.TEMP: air temperature
- C.TEMP: coolant temperature
- Fuel meter
- FUEL CON: amount of fuel consumed
- TRIP TIME: running time
- : cruise control speed setting

Operate the vehicle information displays as follows:

Rotate the wheel switch to move the cursor over an information display. Push the wheel switch inward and the selected display will highlight grey. Rotate the wheel switch to choose a different display item. Push the wheel switch inward to confirm the new display item.

TIP

- In LAP TIME mode, the two vehicle information displays on the main display screen are replaced by lap information.
- TRIP1, TRIP2, F-TRIP, F.AVE, FUEL CON and TRIP TIME items can be individually reset.

Odometer:



The odometer shows the total distance traveled by the vehicle.

TIP

ODO will lock at 999999 and cannot be reset.

Fuel reserve tripmeter:



When the fuel tank reserve level has been reached, F-TRIP appears automatically and begins recording distance traveled from that point. After refueling and traveling some distance, F-TRIP will automatically disappear.

Tripmeters:

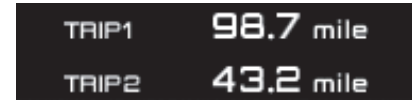

TRIP1 and TRIP2 show the distance traveled since they were last set to zero.

TIP

TRIP1 and TRIP2 will reset to 0 and begin counting again after 9999.9 has been reached.

Average fuel economy:



When using kilometers, the average fuel economy display can be set to “km/L” or “L/100km”. See page 5-18.

TIP

After resetting the average fuel economy display, “--.” will be shown until the vehicle has traveled 1 km (0.6 mi).

Instantaneous fuel economy:



When using kilometers, the instant fuel economy display can be set to “km/L” or “L/100km”. See page 5-18.

TIP

If traveling at speeds under 10 km/h (6 mi/h), “--.” will be displayed.

Air temperature:



The air temperature is displayed from -9°C (16°F) to 50°C (122°F) in 1°C (1°F) increments. The temperature displayed may vary from the actual ambient temperature.

TIP

- “--.” will be displayed if the detected temperature is lower.
- “--.” will be displayed if the detected temperature is higher.

Coolant temperature:



The coolant temperature is displayed from 40°C (104°F) to 124°C (255°F) in 1°C (1°F) increments.

TIP

- If the vehicle coolant temperature is below 40°C (104°F) the coolant temperature display will read “Lo”
- If the vehicle coolant temperature is above 124°C (255°F) the coolant temperature display will read “Hi”

Fuel Meter:



The fuel meter indicates the amount of fuel in the fuel tank. The display segments of the fuel meter disappear from “F” (full) towards “E” (empty) as the fuel level decreases. When the last segment starts flashing, refuel as soon as possible.

Fuel consumption trip meter:



Instrument and control functions

Displays how much trip fuel has been consumed since the trip meter was last reset.

TIP

The instantaneous fuel consumption function should be used for general reference only. Do not use this figure to estimate the distance that can be traveled on the current tank of fuel.

5

Trip time:



Displays engine running time.

Cruise control speed setting:



Displays the selected speed setting for the cruise control system. To adjust this speed setting, see page 4-1 for an explanation of the cruise control system.

To reset information display items (if able):

1. Rotate the wheel switch to highlight one of the six vehicle information displays.
2. Press the wheel switch inward to select the information display.
3. Rotate the wheel switch to select the desired information display item.
4. Press and hold the wheel switch inward until the display item is reset.

Transmission gear display

This shows which gear the transmission is in. This model has 6 gears and a neutral position. The neutral position is indicated by the neutral indicator light “N” and by the transmission gear display “N”.

MODE display

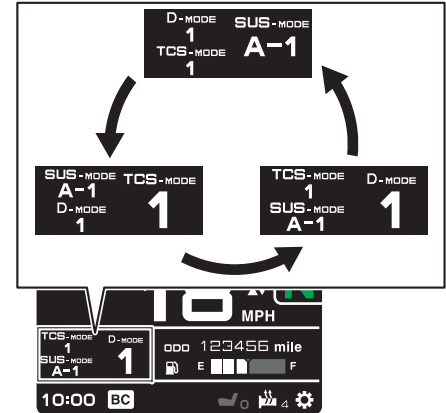

This display shows the currently selected “D-MODE”, “SUS-MODE” and “TCS-MODE” settings. The mode that is enlarged and displayed on the right can be adjusted using the MODE up/down switches. Use the “MODE” switch to rotate counterclockwise between “TCS-MODE”, “SUS-MODE” and “D-MODE”.

See page 4-3 for information on “D-MODE”, “TCS-MODE” and “SUS-MODE” settings.

TIP

- When the engine trouble warning light “

To turn off the traction control system, select “TCS-MODE” with the “MODE” switch, then push and hold the MODE up switch until “OFF” is displayed. To turn TCS back on, press the MODE down switch (“TCS-MODE” will return to its previous setting).

TIP



- When “TCS-MODE” has been set to “OFF”, the TCS, SCS and LIF systems are all turned off together.



- The “TCS-MODE OFF” and “TCS-MODE M” settings can only be selected while the vehicle is stopped.



Clock

The clock uses a 12-hour time system. See page 5-19 to set the clock.

Quick shift indicator “QS”

When able to shift, the respective QS  or  turns green.

When unable to shift, QS   is white.

If the QS function is turned OFF, QS   itself is not displayed.

The QS functions can be turned on or off in the setting MENU. See page 5-16.

TIP

The upshift and downshift functions are independent and can be activated separately.

For more information on the QS system see “QSS” on page 4-6.

Setting MENU icon “ Choose this icon and push the wheel switch to access the settings MENU. (See page 5-15.)

Grip warmer indicator

The grip warmers can be used when the engine is running. There are 10 temperature levels. When activated, the indicator will display the temperature level from 1 (lowest) to 10 (highest).

To activate the grip warmer, use the wheel switch to highlight the grip warmer display with the cursor.

Press the wheel switch inward to select the grip warmer function.

Once selected, rotate the wheel switch up and down to adjust the temperature level.

Press the wheel switch inward to confirm the temperature level and exit the grip warmer function.

ECA17982

NOTICE

- Be sure to wear gloves when using the grip warmers.
- Do not use the grip warmers in warm weather.

Instrument and control functions

- If the handlebar grip or throttle grip becomes worn or damaged, stop using the grip warmers and replace the grips.

Seat heater indicator (if equipped)

The seat heater can be used when the engine is running. There are 10 temperature levels. When activated, the indicator will display the temperature level from 1 (lowest) to 10 (highest).

To activate the seat heater, use the wheel switch to highlight the seat heater display with the cursor.

Press the wheel switch inward to select the seat heater function.

Once selected, rotate the wheel switch up and down to adjust the temperature level.

Press the wheel switch inward to confirm the temperature level and exit the seat heater function.

ECA25721

NOTICE

- Be sure to wear protective clothing that covers your hip and legs when using the seat heater.

- Do not use the seat heater in warm weather.
- If the seat becomes worn or damaged, stop using the seat heater and replace the seat.

The function of the wheel switch can be locked into grip warmer/seat heater mode by pressing and holding the wheel switch inward while the grip warmer indicator or the seat heater indicator is highlighted by the cursor.

In this mode, the temperature levels can be instantly adjusted by rotating the wheel switch up/down.

While in this mode, press the wheel switch inward to toggle between the grip warmer and seat heater functions. To exit this mode and return the wheel switch to its normal functionality, press and hold the wheel switch inward.

TIP

The current grip warmer/seat heater settings are saved when the vehicle is turned off.

Lap timer

This stopwatch function can be activated through the settings MENU. (See page 5-15.)

Once activated, the two vehicle information displays on the main display screen are replaced with:

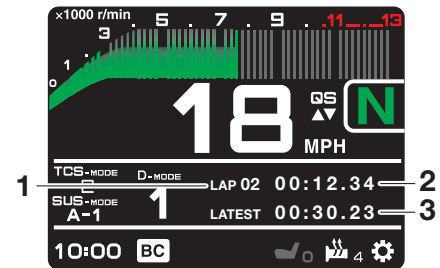

1. Lap count
2. Current lap time
3. Latest/Previous lap time

To start the timer, push the dimmer/pass switch down towards “PASS”.

Each push of the dimmer/pass switch will increase the lap count by 1 and reset the current lap timer.

To pause the lap timer, press the wheel switch inward.

To unpause the timer, push the dimmer/pass switch down towards “PASS” and the timer will resume without counting a new lap.

To exit the lap time mode, turn it off in the settings MENU. (See page 5-15.)

TIP

- The engine must be running to start the lap timer.
- The headlight will flash when the dimmer/pass switch is pressed.
- Whenever the lap timer is paused, it can be resumed using the dimmer/pass switch.

Brake control icon “BC”

This icon is replaced by the auxiliary system warning and coolant temperature warning indicators when they are activated.

For more information on the BC system see “BC” on page 4-7.

Error mode warning “Err”

When an internal error occurs (e.g., communication with a system controller has been cut off), the error mode warning will appear as follows.

“Err” and “

“Err” and the SCU trouble warning “

“Err” only indicates an ABS ECU error.

TIP

Depending on the nature of the error, the display may not function properly and the TCS settings may be impossible to change. Additionally, the ABS may not function properly. Use extra care when braking and have a Yamaha dealer check the vehicle immediately.

SCU trouble warning “ This icon appears if a problem is detected in the front or rear suspension.

Auxiliary system warning “ This icon appears if a problem is detected in a non-engine-related system.

Coolant temperature warning “ This icon appears if the coolant temperature reaches 116 °C (241 °F) or higher. Stop the vehicle and turn off the engine. Allow the engine to cool.

NOTICE

Do not continue to operate the engine if it is overheating.

Oil pressure warning “ This icon appears when the engine oil pressure is low. When the vehicle is first turned on, engine oil pressure has yet to build, so this icon will come on and stay on until the engine has been started.

TIP

If a malfunction is detected, the oil pressure warning icon will flash repeatedly.

NOTICE

Do not continue to operate the engine if the oil pressure is low.

Instrument and control functions

EAU92793

Settings MENU

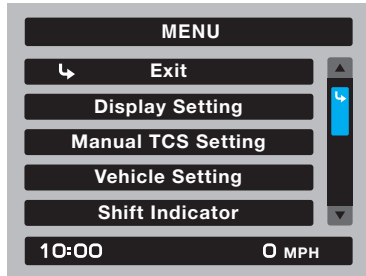

5

The settings MENU screen contains the following settings modules. Select a module to make related settings changes.

Module	Description
“Exit”	Exit MENU and return the main display
“Display Setting”	Switch lap time mode on/off and adjust the tachometer color
“Manual TCS Setting”	Adjust TCS/SCS/LIF settings for the “TCS-MODE M”
“Vehicle Setting”	Adjust BC/QS settings
“Shift Indicator”	Turn the shift indicator on/off and adjust tachometer settings
“Maintenance”	View and reset maintenance intervals

“Unit”	Set fuel consumption and measurement units
“Brightness”	Adjust screen brightness
“Clock”	Adjust the clock
“SUS. Sensor Calibration”	Perform a sensor calibration
“All Reset”	Return all settings to factory default

Settings MENU access and operation

How to use the settings MENU:

Rotate the wheel switch up or down to highlight items or increase/decrease values and briefly press the wheel switch inward to confirm the selection. Press and hold the wheel switch until the screen returns to the main display to exit the MENU at any time.

TIP

- Certain settings menu screens have an upward pointing triangle mark item. Select the triangle mark to save settings changes and exit the current screen.
- Should vehicle motion be detected, the screen will automatically exit the settings MENU and return to the main display.

- To ensure that the desired settings changes are saved, be sure to exit each menu via the triangle mark (if displayed). Exiting the settings menu by pressing and holding the wheel switch may not save settings changes.

“Display Setting”

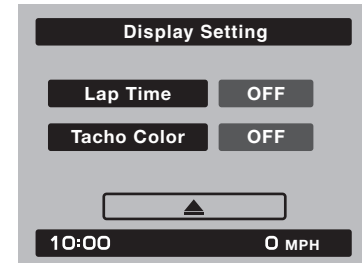

This module allows you to switch the lap time mode and tachometer color mode ON/OFF.

When the lap time mode is ON, the twin vehicle information displays on the main display screen will show a lap timer and a lap counter. To exit the lap time mode, the turn lap timer OFF in the Display Setting module.

Instrument and control functions

To change the tachometer to color mode, select ON.

“Manual TCS Setting”

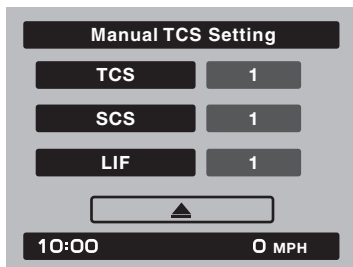

This module allows you to customize the “TCS-MODE M” which is accessible on the main display using the MODE switches.

TCS

This model uses a variable traction control system. For each setting level, the further the vehicle is leaned over, the greater the amount of traction control (system intervention) is applied.

There are 3 setting levels available for the “TCS-MODE M”.

Setting level 1 applies the least amount of overall system intervention, while setting level 3 applies the greatest amount of overall traction control.

TIP

- TCS can only be turned on or off via the main display using the MODE switches.
- SCS and LIF can be turned off independently of TCS for “TCS-MODE M”.
- When “TCS-MODE” has been set to “OFF” on the main display: TCS, SCS and LIF are all turned off together.

SCS

SCS can be set to OFF, 1, 2, and 3. OFF turns the slide control system off, setting level 1 provides the least amount of system intervention, and setting level 3 provides the greatest amount of system intervention.

LIF

LIF can be set to OFF, 1, 2, and 3.

Setting level 1 provides the least amount of system intervention and setting 3 most strongly reduces the rate of wheel lift.

OFF turns LIF off.

“Vehicle Setting”

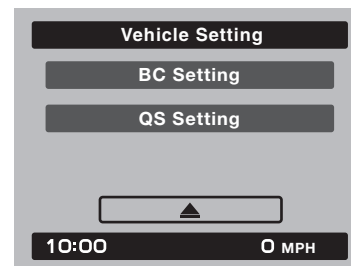

The vehicle setting module allows you to adjust settings for the BC and QS systems.

Instrument and control functions

BC

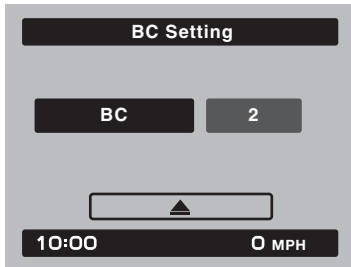

QS

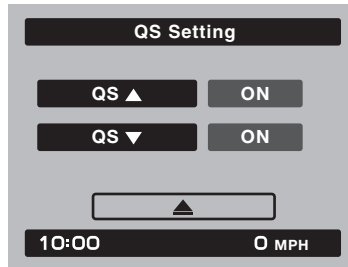

“Shift Indicator”

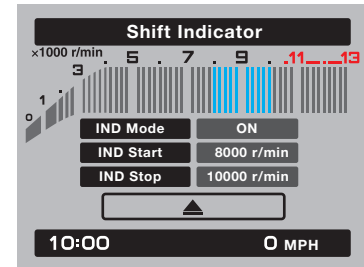

5

The brake control system has two settings, BC1 and BC2. Select BC1 when only standard ABS is desired. Select BC2 to have the brake control system further regulate brake pressure while cornering to suppress lateral wheel slip.

TIP

For skilled riders and when riding at the track, due to varying conditions, the BC2 brake system may engage sooner than expected relative to your desired cornering speed or intended cornering line.

The quick shift system indicators are divided into QS▲ and QS▼ sections. QS▲ and QS▼ are not linked and can be independently turned on or off. QS can be set to ON or OFF. OFF turns the respective upshift or downshift function off, and the clutch lever must then be used when shifting in that direction.

TIP

If the QSS setting cannot be changed: turn the engine off with the gear position set to neutral, then change the setting.

This module allows a custom shift indicator to be set. When the engine r/min (rotations per minute) are in the specified range, the gear indicator will flash. This module has 3 options: “IND Mode” - the shift indicator can be turned ON/OFF “IND Start” - the r/min at which the indicator starts flashing can be chosen. Once selected, rotate the wheel switch up/down to increase or decrease the r/min value by increments of 200 r/min. “IND Start” is settable between 6000 - 12800 r/min. “IND Stop” - the r/min at which the indicator stops flashing can be chosen. Once selected, rotate the wheel switch up/down to increase or decrease the

Instrument and control functions

r/min value by increments of 200 r/min. “IND Stop” is settable between 6200 - 13000 r/min.

“Maintenance”

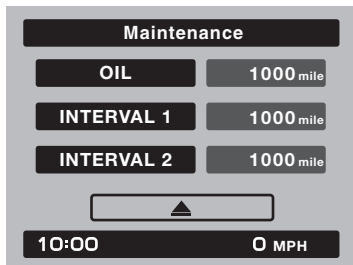

This module allows you to record the distance traveled between engine oil changes (use the OIL item), and for two other items of your choice (use INTERVAL 1 and INTERVAL 2).

To reset a maintenance trip meter, select it and then press and hold the wheel switch.

TIP _____
Maintenance item names cannot be changed.

“Unit”

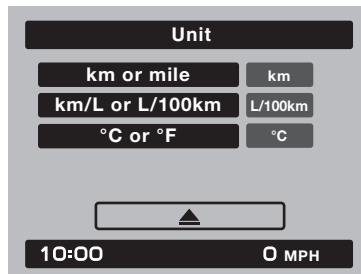

This module allows you to switch the display between metric and imperial measurement units.

When using kilometers, the fuel consumption units can be changed between “km/L” or “L/100km”. When using miles, MPG will be available.

Temperature units can be switched between Celsius and Fahrenheit.

“Brightness”

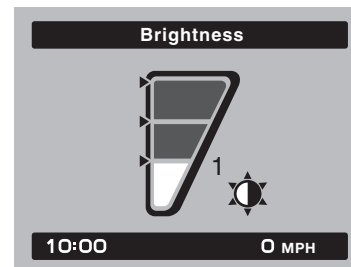

This module allows you to adjust the general brightness level of the display screens.

Select the desired brightness level by rotating the wheel switch, and then press the wheel switch to fix the setting and return to the top MENU screen.

Instrument and control functions

“Clock”

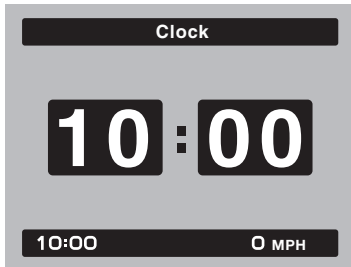

“SUS. Sensor Calibration”

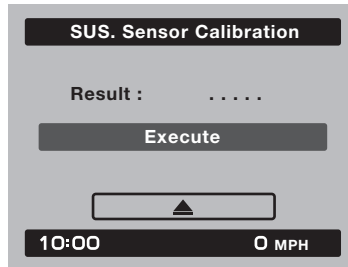

“All Reset”

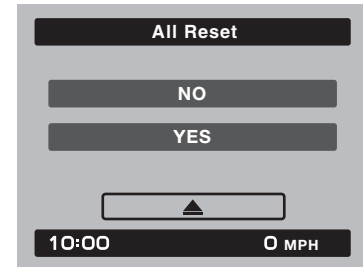

5

This module allows you to set the clock.

When the clock module is selected, the hours will be highlighted.

Set the hours by rotating the wheel switch. Push the switch to confirm and highlight the minutes.

After confirming the minutes, you will be returned to the top MENU screen.

After any service to the rear suspension, a sensor calibration must be performed using this module.

Select “Execute” and within approx. 10 seconds the result of the calibration (success/failed) will be displayed.

TIP

When performing the sensor calibration, place the motorcycle on the centerstand and there should be no weight on the motorcycle.

This module resets all settings items (except the odometers, Clock and SUS. Sensor Calibration) to their default or factory presets.

Select YES to reset all items. After selecting YES, all items will be reset and the screen will automatically return to the top MENU screen.

Clutch lever

EAU12823

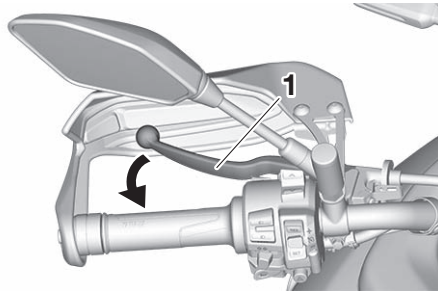

1. Clutch lever

To disengage the drivetrain from the engine, such as when shifting gears, pull the clutch lever toward the handlebar. Release the lever to engage the clutch and transmit power to the rear wheel.

TIP

The lever should be pulled rapidly and released slowly for smooth shifting. (See page 7-3.)

Shift pedal

EAU83690

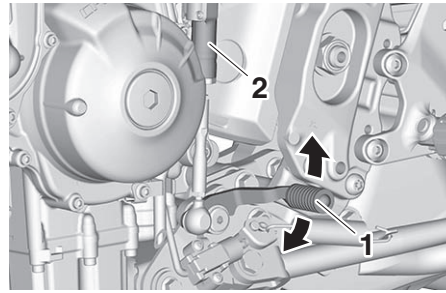

1. Shift pedal

2. Shift sensor

The shift pedal is located on the left side of the motorcycle. To shift the transmission to a higher gear, move the shift pedal up. To shift to the transmission to a lower gear, move the the shift pedal down. (See page 7-3.)

The shift rod is equipped with a shift sensor, which is part of the quick shift system. The shift sensor reads up and down movement, as well as the strength of the input force when the shift pedal is moved.

TIP

To prevent unintended shifts, QSS is programmed to ignore unclear input signals. Therefore, be sure to shift using quick and sufficiently forceful inputs.

Instrument and control functions

EAU26827

Brake lever

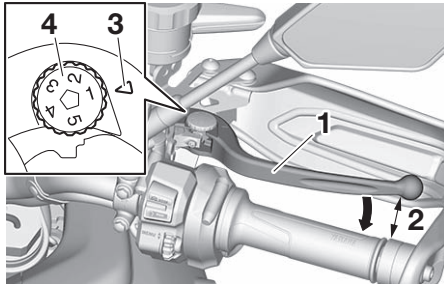

1. Brake lever
2. Distance
3. Match mark
4. Adjusting dial

The brake lever is located on the right side of the handlebar. To apply the front brake, pull the lever toward the throttle grip.

The brake lever is equipped with a brake lever position adjusting dial. To adjust the distance between the brake lever and the throttle grip, push the brake lever away from the throttle grip and rotate the adjusting dial. Make sure the setting number on the adjusting dial aligns with the match mark on the brake lever.

EAU12944

Brake pedal

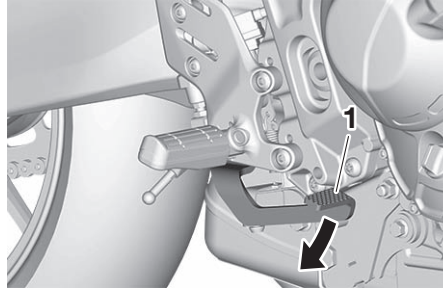

1. Brake pedal

The brake pedal is located on the right side of the motorcycle. To apply the rear brake, press down on the brake pedal.

EAU91461

Brake control system (BC)

The brake control system regulates hydraulic brake pressure for the front and rear wheels independently when the brakes are applied and wheel lock is detected. This system has two settings which can be changed in the settings MENU. (See page 5-16.)

BC1 is standard ABS, which adjusts brake pressure based on vehicle speed and wheel speed data. BC1 is designed to engage and maximize braking when the vehicle is upright. BC2 uses additional data from the IMU to regulate applied brake power when cornering to suppress lateral wheel slip.

Regarding ABS, operate the brakes as you would conventional brakes. When the brake control system engages, a pulsating sensation may be felt at the brake lever or brake pedal as the hydraulic unit rapidly applies and reduces brake pressure. In this situation, continue to apply the brake lever and brake pedal to allow the ABS to work—do not “pump the brakes” as this will reduce braking effectiveness.

EWA16051

WARNING

Always keep a sufficient distance from the vehicle ahead to match the riding speed even with ABS.

- The ABS performs best with long braking distances.
- On certain surfaces, such as rough or gravel roads, the braking distance may be longer with the ABS than without.

The ABS hydraulic unit is monitored by the ABS ECU, which will revert the system to conventional braking if a malfunction occurs.

EWA20891

WARNING

The brake control system is not a substitute for the use of proper riding and braking techniques. The brake control system cannot prevent all loss of traction due to over-braking from excessive speed, or lateral wheel slip when braking on slippery surfaces.

TIP

The ABS performs a self-diagnostic test when the vehicle is started and reaches a speed of 5 km/h (3 mi/h). During this test, a clicking noise may be audible from the hydraulic control unit, and a vibration may be felt at the brake lever or pedal, but this is normal.

ECA20100

NOTICE

Be careful not to damage the wheel sensor or wheel sensor rotor; otherwise, improper performance of the ABS will result.

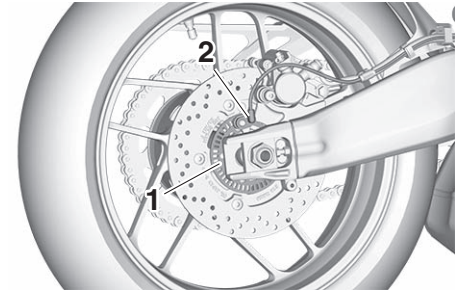

1. Rear wheel sensor rotor
2. Rear wheel sensor

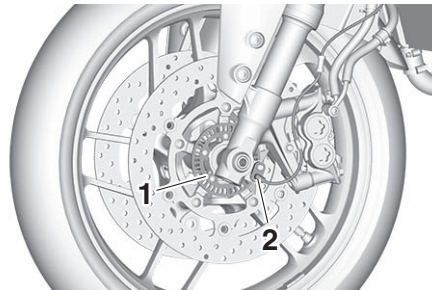

1. Front wheel sensor rotor
2. Front wheel sensor

Instrument and control functions

Fuel tank cap

EAU13077



1. Fuel tank cap lock cover
2. Unlock.

To open the fuel tank cap

Open the fuel tank cap lock cover, insert the key, and then turn it 1/4 turn clockwise. The lock will be released and the fuel tank cap can be opened.

To close the fuel tank cap

With the key still inserted, push down the fuel tank cap. Turn the key 1/4 turn counterclockwise, remove it, and then close the lock cover.

TIP

The fuel tank cap cannot be closed unless the key is in the lock. In addition, the key cannot be removed if the cap is not properly closed and locked.

WARNING

Make sure that the fuel tank cap is properly closed after filling fuel. Leaking fuel is a fire hazard.

EWA11092

Fuel

EAU13222

Make sure there is sufficient gasoline in the tank.

EWA10882

WARNING

Gasoline and gasoline vapors are extremely flammable. To avoid fires and explosions and to reduce the risk of injury when refueling, follow these instructions.

1. Before refueling, turn off the engine and be sure that no one is sitting on the vehicle. Never refuel while smoking, or while in the vicinity of sparks, open flames, or other sources of ignition such as the pilot lights of water heaters and clothes dryers.
2. Do not overfill the fuel tank. When refueling, be sure to insert the pump nozzle into the fuel tank filler hole. Stop filling when the fuel reaches the bottom of the filler tube. Because fuel expands when it heats up, heat from the engine or the sun can cause fuel to spill out of the fuel tank.

Instrument and control functions

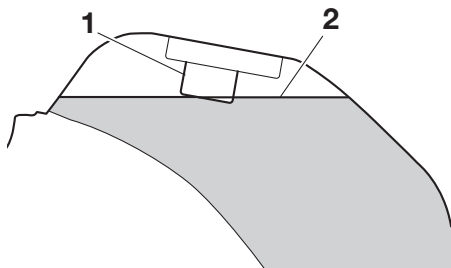

1. Fuel tank filler tube
2. Maximum fuel level

3. Wipe up any spilled fuel immediately. **NOTICE: Immediately wipe off spilled fuel with a clean, dry, soft cloth, since fuel may deteriorate painted surfaces or plastic parts.** [ECA10072]
4. Be sure to securely close the fuel tank cap.

EWA15152

WARNING

Gasoline is poisonous and can cause injury or death. Handle gasoline with care. Never siphon gasoline by mouth. If you should swallow some gasoline or inhale a lot of gasoline vapor, or get some gasoline in your eyes, see your doctor immedi-

ately. If gasoline spills on your skin, wash with soap and water. If gasoline spills on your clothing, change your clothes.

EAU86110

Your Yamaha engine was designed to use premium unleaded gasoline. Confirm the pump octane number [(R+M)/2 method] is 91 or higher, or the research octane number (RON) is 95 or higher. If engine knocking or pinging occurs, use a gasoline of a different brand or higher octane rating.

Recommended fuel:

Unleaded gasoline (E10 acceptable)

Octane number (R+M)/2:

91 or higher

Fuel tank capacity:

19 L (5.0 US gal, 4.2 Imp.gal)

Fuel reserve amount:

3.0 L (0.79 US gal, 0.66 Imp.gal)

Gasohol

There are two types of gasohol: gasohol containing ethanol and that containing methanol. Gasohol containing ethanol can be used if the ethanol content does not exceed 10% (E10). Gas-

ohol containing methanol is not recommended by Yamaha because it can cause damage to the fuel system or vehicle performance problems.

ECA11401

NOTICE

Use only unleaded gasoline. The use of leaded gasoline will cause severe damage to internal engine parts, such as the valves and piston rings, as well as to the exhaust system.

Instrument and control functions

EAU86260

Fuel tank breather hose and overflow hose

For U49 models

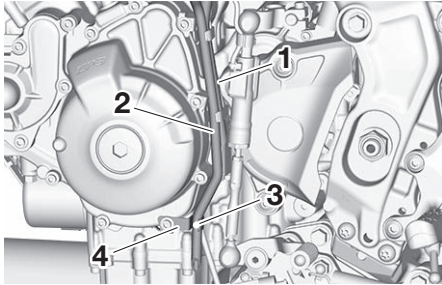

1. Fuel tank breather hose
2. Fuel tank overflow hose
3. Original position (paint mark)
4. Clamp

For California

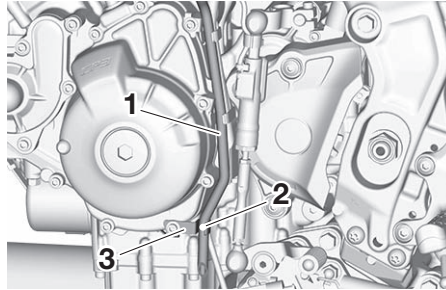

1. Fuel tank overflow hose
2. Original position (paint mark)
3. Clamp

The breather hose prevents a vacuum condition from forming within the fuel tank.

The overflow hose drains excess gasoline and directs it safely away from the vehicle.

Before operating the vehicle:

- check each hose connection.
- check each hose for damage.
- confirm the end of each hose is not blocked.
- confirm each hose is positioned as shown.

TIP

For California: See page 8-10 for canister information.

Catalytic converter

EAU13435

The exhaust system contains catalytic converter(s) to reduce harmful exhaust emissions.

EWA10863

WARNING

The exhaust system is hot after operation. To prevent a fire hazard or burns:

- Do not park the vehicle near possible fire hazards such as grass or other materials that easily burn.
- Park the vehicle in a place where pedestrians or children are not likely to touch the hot exhaust system.
- Make sure that the exhaust system has cooled down before doing any maintenance work.
- Do not allow the engine to idle more than a few minutes. Long idling can cause a build-up of heat.

Seats

EAU92640

Passenger seat

To remove the passenger seat

1. Insert the key into the seat lock, and then turn it counterclockwise.

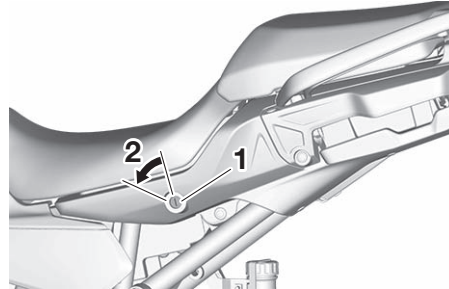

1. Seat lock
2. Unlock.

2. Lift the front of the passenger seat and pull it forward.

To install the passenger seat

1. Insert the projections on the rear of the passenger seat into the seat holders as shown, and then push the front of the seat down to lock it in place.

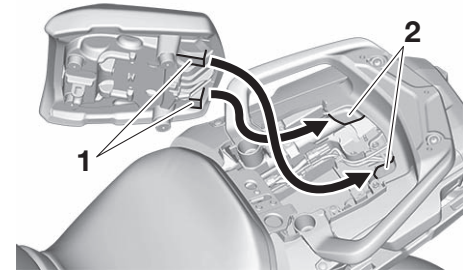

1. Projection
2. Seat holder

2. Remove the key.

Rider seat

To remove the rider seat

1. Remove the passenger seat.
2. Remove the cap, then push the rider seat lock lever, located under the back of the rider seat, to the left as shown, and then pull the seat off.

Instrument and control functions

5

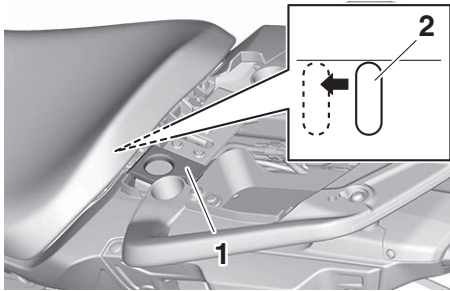

1. Cap
2. Rider seat lock lever

2. Install the cap.

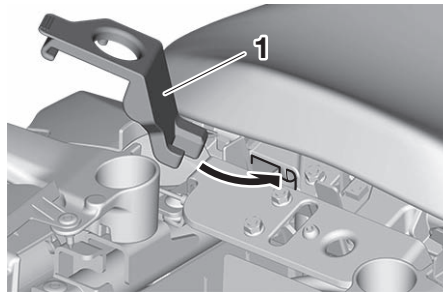

1. Cap

3. Install the passenger seat.

To install the rider seat

1. Insert the projection on the front of the rider seat into the seat holder as shown, and then push the rear of the seat down to lock it in place.

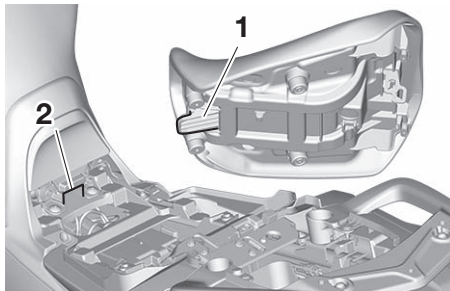

1. Projection
2. Seat holder

TIP

- Make sure that the seats are properly secured before riding.
- The rider seat height can be adjusted. See the following section.

EAU92633

Adjusting the rider seat height

The rider seat height can be adjusted to one of two positions.

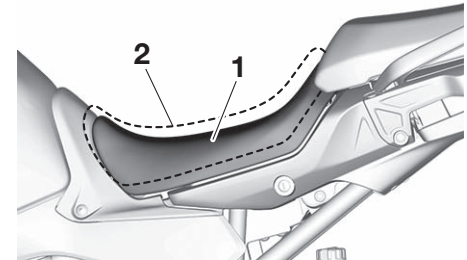

1. Low position
2. High position

To change to the high position

1. Remove the passenger seat and rider seat.
2. Remove the rider seat height position adjuster by pulling it upward.

Instrument and control functions

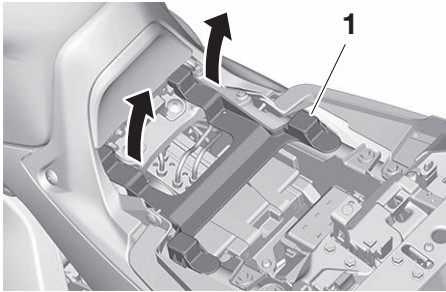

1. Rider seat height position adjuster

3. Install the rider seat height position adjuster by inserting the front projections into the grommets.

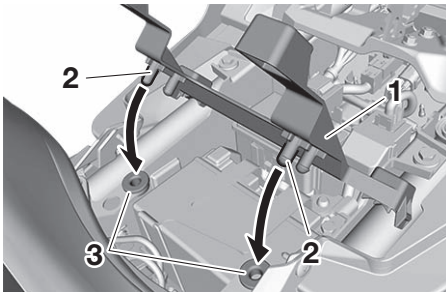

1. Rider seat height position adjuster
2. Projection
3. Grommet

4. Remove the rubber cover.

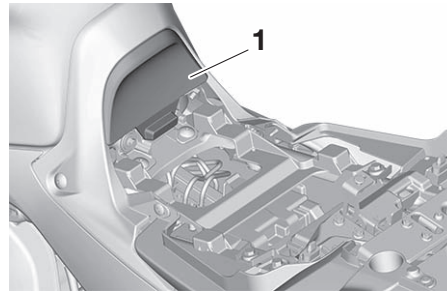

1. Rubber cover

TIP

Do not lose the rubber cover.

5. Insert the projection on the front of the rider seat into seat holder B as shown.

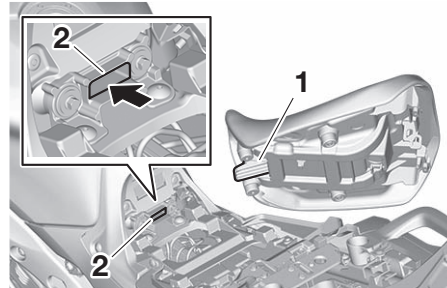

1. Projection
2. Seat holder B (for high position)

6. Align the projection on the bottom of the rider seat with the "H" position slot, and then push the rear of the seat down to lock it in place as shown.

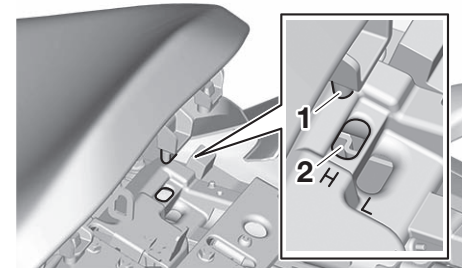

1. Projection
2. "H" position slot

7. Install the passenger seat.

To change to the low position

1. Remove the passenger seat and rider seat.
2. Remove the rider seat height position adjuster by pulling it upward.
3. Install the rider seat height position adjuster by inserting the rear projections into the grommets.

Instrument and control functions

5

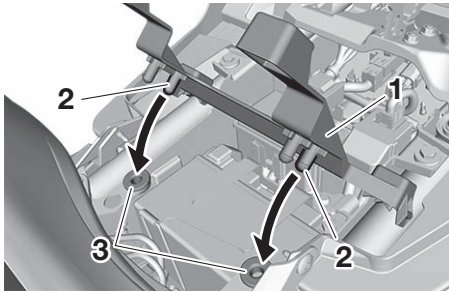

1. Rider seat height position adjuster
2. Projection
3. Grommet

4. Install the rubber cover.

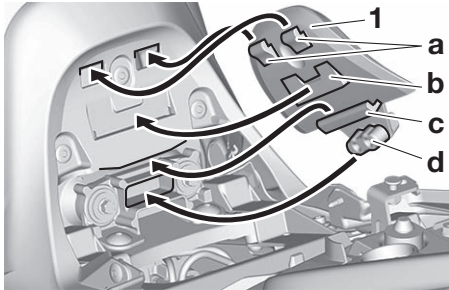

1. Rubber cover

TIP _____
 Insert the projections in order from a to d.

5. Insert the projection on the front of the rider seat into seat holder A as shown.

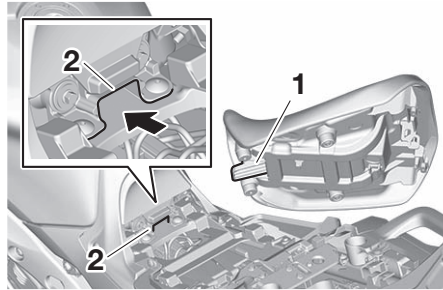

1. Projection
2. Seat holder A (for low position)

6. Align the projection on the bottom of the rider seat with the “L” position slot, and then push the rear of the seat down to lock it in place as shown.



1. Projection
2. “L” position slot

7. Install the passenger seat.

TIP _____
 Make sure that the seats are properly secured before riding.

Rider footrest position

EAU91560

The rider footrests can be adjusted to one of two positions. From the factory, the footrests are in the low position. Have a Yamaha dealer adjust the positions of the rider footrests.

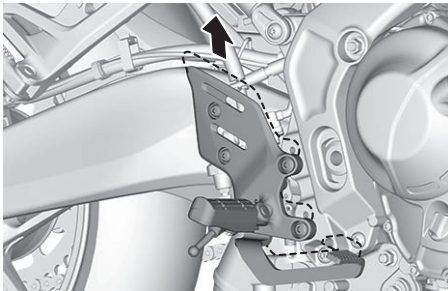
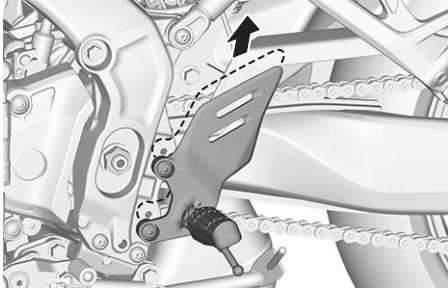

Storage compartment

EAU62550

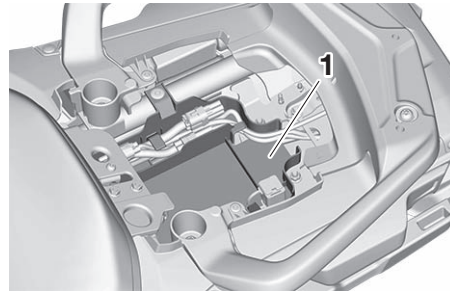

1. Storage compartment

The storage compartment is located under the passenger seat. (See page 5-26.)

When storing documents or other items in the storage compartment, be sure to wrap them in a plastic bag so that they will not get wet. When washing the vehicle, be careful not to let any water enter the storage compartment.

EWA15401

⚠ WARNING

Do not exceed the maximum load of 193 kg (425 lb) for the vehicle.

Windshield

EAU83932

This model is equipped with an adjustable windshield.

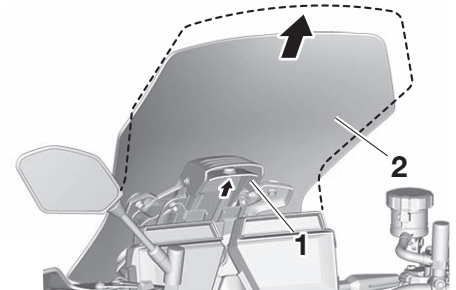

1. Windshield lock lever
2. Windshield

To change the position of the windshield, lift up the windshield lock lever and slide the windshield up or down. Release the lock lever when finished.

TIP

Make sure the windshield and lock lever are properly secured before riding.

Instrument and control functions

Handlebar position

EAU46833

The handlebar can be adjusted to one of two positions to suit the rider's preference. Have a Yamaha dealer adjust the position of the handlebar.

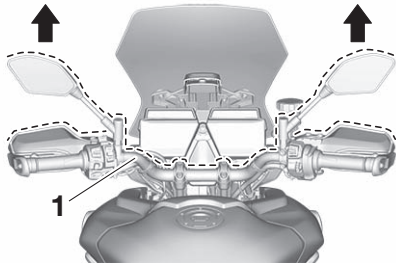

1. Handlebar

5

Adjusting the front and rear suspension

EAU92782

This model is equipped with an electronically controlled suspension damping system (KADS). See pages 4-4, 5-11 for more information on KADS and SUS-MODE.

TIP

After any service to the rear suspension, a sensor calibration must be performed via the settings MENU. See page 5-19 for more information on SUS. Sensor Calibration.

Spring preload of the front fork

EWA10181

WARNING

Always adjust both fork legs equally, otherwise poor handling and loss of stability may result.

ECA27260

NOTICE

Use extra care to avoid scratching the anodized finish when making suspension adjustments.

Turn the adjusting nut in direction (a) to increase the spring preload.

Turn the adjusting nut in direction (b) to decrease the spring preload.

To set the spring preload, turn the adjuster in direction (b) until it stops, and then count the turns in direction (a).

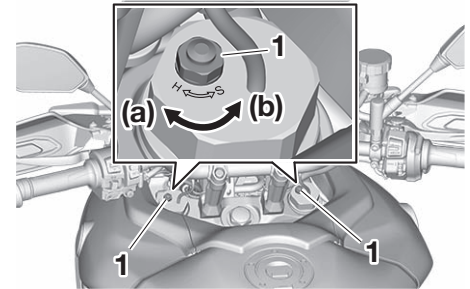

1. Spring preload adjusting nut

Spring preload setting:

- Minimum (soft):
0 turn(s) in direction (a)
- Standard:
2 turn(s) in direction (a)
- Maximum (hard):
10 turn(s) in direction (a)

Spring preload of the shock absorber assembly

EWA10222



WARNING

This shock absorber assembly contains highly pressurized nitrogen gas. Read and understand the following information before handling the shock absorber assembly.

- Do not tamper with or attempt to open the cylinder assembly.
- Do not subject the shock absorber assembly to an open flame or other high heat source. This may cause the unit to explode due to excessive gas pressure.
- Do not deform or damage the cylinder in any way. Cylinder damage will result in poor damping performance.
- Do not dispose of a damaged or worn-out shock absorber assembly yourself. Take the shock absorber assembly to a Yamaha dealer for any service.

Turn the adjusting knob in direction (a) to increase the spring preload.

Turn the adjusting knob in direction (b) to decrease the spring preload.

To set the spring preload, turn the adjuster in direction (b) until it stops, and then count the clicks in direction (a).

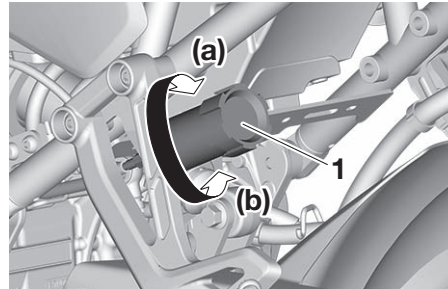

1. Spring preload adjusting knob

Spring preload setting:

Minimum (soft):

1 click(s) in direction (a)

Standard:

11 click(s) in direction (a)

Maximum (hard):

24 click(s) in direction (a)

TIP

When turning the spring preload adjuster in direction (b), the 0 click position and the 1 click position may be the same.

Luggage strap holders

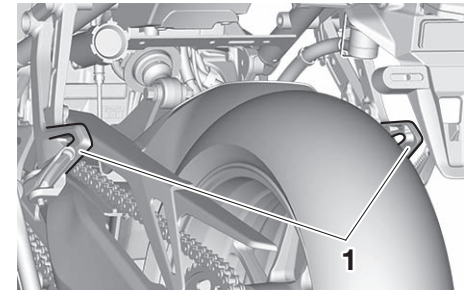

1. Luggage strap holder

Use the indicated strap points to secure luggage ties to the vehicle.

Instrument and control functions

Auxiliary DC jack

EAU49454

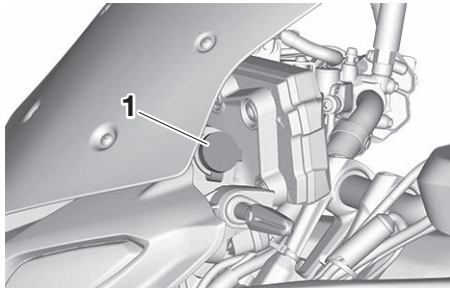

1. Auxiliary DC jack cap

A 12-V accessory connected to the auxiliary DC jack can be used when the main switch is on.

ECA15432

NOTICE

The accessory connected to the auxiliary DC jack should not be used with the engine turned off, and the load must never exceed 24 W (2 A), otherwise the fuse may blow or the battery may discharge.

To use the auxiliary DC jack

1. Turn the main switch off.
2. Remove the auxiliary DC jack cap.
3. Turn the accessory off.

4. Insert the accessory plug into the auxiliary DC jack.

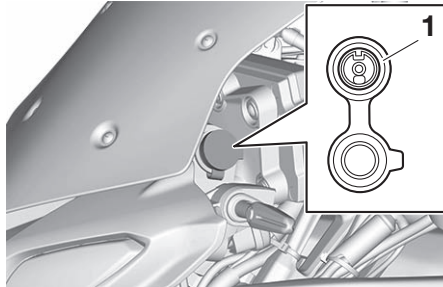

1. Auxiliary DC jack

5. Turn the main switch on, and start the engine. (See page 7-2.)
6. Turn the accessory on.

EWA14361

WARNING

To prevent electrical shock or short-circuiting, make sure that the cap is installed when the auxiliary DC jack is not being used.

Auxiliary DC connector

EAU70641

This vehicle is equipped with an auxiliary DC connector. Consult your Yamaha dealer before installing any accessories.

Sidestand

EAU15306

The sidestand is located on the left side of the frame. Raise the sidestand or lower it with your foot while holding the vehicle upright.

TIP

The built-in sidestand switch is part of the ignition circuit cut-off system, which cuts the ignition in certain situations. (See the following section for an explanation of the ignition circuit cut-off system.)

EWA10242

WARNING

The vehicle must not be ridden with the sidestand down, or if the sidestand cannot be properly moved up (or does not stay up), otherwise the sidestand could contact the ground and distract the operator, resulting in a possible loss of control. Yamaha's ignition circuit cut-off system has been designed to assist the operator in fulfilling the responsibility of raising the sidestand before starting off. Therefore, check

this system regularly and have a Yamaha dealer repair it if it does not function properly.

Ignition circuit cut-off system

EAU44905

This system prevents in-gear engine starts unless the clutch lever is pulled and the sidestand is up. Also, it will stop the running engine should the sidestand be lowered while the transmission is in gear.

Periodically check the system via the following procedure.

TIP

- This check is most reliable if performed with a warmed-up engine.
- See pages 5-1 and 5-2 for switch operation information.

Instrument and control functions

5

With the engine turned off:
1. Place vehicle on centerstand.
2. Move the sidestand down.
3. Set engine stop switch to run position.
4. Turn main switch to on position.
5. Shift transmission into neutral.
6. Push the start switch.
Does the engine start?

YES NO

With the engine still running:
7. Move the sidestand up.
8. Pull the clutch lever.
9. Shift transmission into gear.
10. Move the sidestand down.
Does the engine stall?

YES NO

After the engine has stalled:
11. Move the sidestand up.
12. Pull the clutch lever.
13. Push the start switch.
Does the engine start?

YES NO

The system is OK. **The motorcycle can be ridden.**

WARNING

- **The vehicle must be placed on the centerstand during this inspection.**
- **If a malfunction is found, have the vehicle inspected before riding.**

The neutral switch may not be working.
The motorcycle should not be ridden until checked by a Yamaha dealer.

The sidestand switch may not be working.
The motorcycle should not be ridden until checked by a Yamaha dealer.

The clutch switch may not be working.
The motorcycle should not be ridden until checked by a Yamaha dealer.

For your safety – pre-operation checks

EAU1559B

Inspect your vehicle each time you use it to make sure the vehicle is in safe operating condition. Always follow the inspection and maintenance procedures and schedules described in the Owner's Manual.

EWA11152

WARNING

Failure to inspect or maintain the vehicle properly increases the possibility of an accident or equipment damage. Do not operate the vehicle if you find any problem. If a problem cannot be corrected by the procedures provided in this manual, have the vehicle inspected by a Yamaha dealer.

Before using this vehicle, check the following points:

ITEM	CHECKS	PAGE
Fuel	<ul style="list-style-type: none">• Check fuel level in fuel tank.• Refuel if necessary.• Check fuel line for leakage.• Check fuel tank breather hose and overflow hose for obstructions, cracks or damage, and check hose connections.	5-23, 5-25
Engine oil	<ul style="list-style-type: none">• Check oil level in engine.• If necessary, add recommended oil to specified level.• Check vehicle for oil leakage.	8-10
Coolant	<ul style="list-style-type: none">• Check coolant level in reservoir.• If necessary, add recommended coolant to specified level.• Check cooling system for leakage.	8-13
Front brake	<ul style="list-style-type: none">• Check operation.• If soft or spongy, have Yamaha dealer bleed hydraulic system.• Check brake pads for wear.• Replace if necessary.• Check fluid level in reservoir.• If necessary, add specified brake fluid to specified level.• Check hydraulic system for leakage.	8-19, 8-20

For your safety – pre-operation checks

ITEM	CHECKS	PAGE
Rear brake	<ul style="list-style-type: none"> • Check operation. • If soft or spongy, have Yamaha dealer bleed hydraulic system. • Check brake pads for wear. • Replace if necessary. • Check fluid level in reservoir. • If necessary, add specified brake fluid to specified level. • Check hydraulic system for leakage. 	8-19, 8-20
Clutch	<ul style="list-style-type: none"> • Check operation. • Lubricate cable if necessary. • Check lever free play. • Adjust if necessary. 	8-18
Throttle grip	<ul style="list-style-type: none"> • Check for smooth rotation and automatic return. 	8-24
Control cables	<ul style="list-style-type: none"> • Make sure that operation is smooth. • Lubricate if necessary. 	8-24
Drive chain	<ul style="list-style-type: none"> • Check chain slack. • Adjust if necessary. • Check chain condition. • Lubricate if necessary. 	8-22, 8-23
Wheels and tires	<ul style="list-style-type: none"> • Check for damage. • Check tire condition and tread depth. • Check air pressure. • Correct if necessary. 	8-15, 8-17
Brake and shift pedals	<ul style="list-style-type: none"> • Make sure that operation is smooth. • Lubricate pedal pivoting points if necessary. 	8-25
Brake and clutch levers	<ul style="list-style-type: none"> • Make sure that operation is smooth. • Lubricate lever pivoting points if necessary. 	8-25
Centerstand, sidestand	<ul style="list-style-type: none"> • Make sure that operation is smooth. • Lubricate pivots if necessary. 	8-26
Chassis fasteners	<ul style="list-style-type: none"> • Make sure that all nuts, bolts and screws are properly tightened. • Tighten if necessary. 	—

For your safety – pre-operation checks

ITEM	CHECKS	PAGE
Instruments, lights, signals and switches	<ul style="list-style-type: none">• Check operation.• Correct if necessary.	—
Sidestand switch	<ul style="list-style-type: none">• Check operation of ignition circuit cut-off system.• If system is not working correctly, have Yamaha dealer check vehicle.	5-34

Operation and important riding points

EAU15952

Read the Owner's Manual carefully to become familiar with all controls. If there is a control or function you do not understand, ask your Yamaha dealer.

EWA10272

WARNING

Failure to familiarize yourself with the controls can lead to loss of control, which could cause an accident or injury.

EAU16842

Engine break-in

There is never a more important period in the life of your engine than the period between 0 and 1600 km (1000 mi). For this reason, you should read the following material carefully.

Since the engine is brand new, do not put an excessive load on it for the first 1600 km (1000 mi). The various parts in the engine wear and polish themselves to the correct operating clearances. During this period, prolonged full-throttle operation or any condition that might result in engine overheating must be avoided.

EAU17094

0–1000 km (0–600 mi)

Avoid prolonged operation above 5300 r/min. **NOTICE: After 1000 km (600 mi) of operation, the engine oil must be changed and the oil filter cartridge or element replaced.** [ECA10303]

1000–1600 km (600–1000 mi)

Avoid prolonged operation above 6300 r/min.

1600 km (1000 mi) and beyond

The vehicle can now be operated normally.

ECA10311

NOTICE

- **Keep the engine speed out of the tachometer red zone.**
 - **If any engine trouble should occur during the engine break-in period, immediately have a Yamaha dealer check the vehicle.**
-

Starting the engine

EAU91811

The ignition circuit cut-off system will enable starting when:

- the transmission is in the neutral position or
- the transmission is in gear, the sidestand is up, and the clutch lever is pulled.

To start the engine

1. Turn the main switch on and set the engine stop switch to the run position.
2. Confirm the indicator and warning light(s) come on for a few seconds, and then go off. (See page 5-5.)

TIP

- Do not start the engine if the engine trouble warning light remains on.
- The oil pressure and coolant temperature warning light should come on and stay on until the engine is started.

- The ABS warning light should come on and stay on until the vehicle reaches a speed of 5 km/h (3 mi/h).

ECA24110

NOTICE

If a warning or indicator light does not work as described above, have a Yamaha dealer check the vehicle.

3. Shift the transmission into the neutral position.
4. Start the engine by pushing the start switch.
5. Release the start switch when the engine starts, or after 5 seconds. Wait 10 seconds before pressing the switch again to allow battery voltage to restore.

TIP

If the engine fails to start, try again with the throttle grip turned by a 1/4 turn (20 degrees) open.

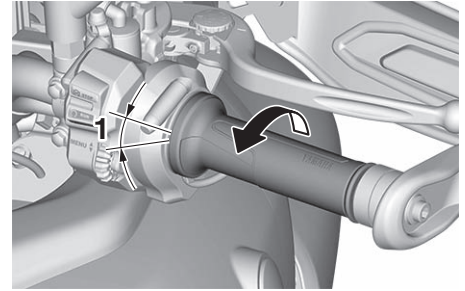

1. 1/4 turn (20 degrees)

ECA11043

NOTICE

For maximum engine life, never accelerate hard when the engine is cold!

Operation and important riding points

EAU68221

EAU91540

ECA22521

TIP

This model is equipped with:

- an inertial measurement unit (IMU). This unit stops the engine in case of a turnover. Turn the main switch off and then on before attempting to restart the engine. Failing to do so will prevent the engine from starting even though the engine will crank when pushing the start switch.
- an engine auto-stop system. The engine stops automatically if left idling for 20 minutes. If the engine stops, simply push the start switch to restart the engine.

Shifting

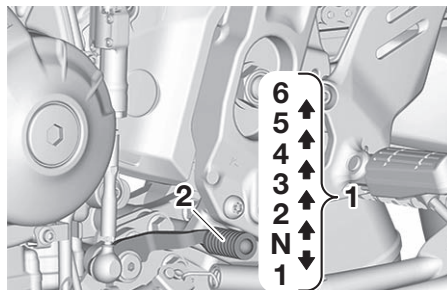

1. Gear positions
2. Shift pedal

Shifting gears lets you control the amount of engine power available for starting off, accelerating, climbing hills, etc. The gear positions are shown in the illustration.

TIP

- To shift the transmission into the neutral position (N), press the shift pedal down repeatedly until it reaches the end of its travel, and then slightly raise it.
- This model is equipped with a quick shift system. (See page 4-6.)

NOTICE

- Even with the transmission in the neutral position, do not coast for long periods of time with the engine off, nor tow the motorcycle for long distances. The transmission is properly lubricated only when the engine is running. Inadequate lubrication may damage the transmission.
- Except when using the quick shift system, always pull the clutch lever when changing gears to avoid damaging the engine, transmission, and drivetrain.

EAU16682

To start out and accelerate

1. Pull the clutch lever to disengage the clutch.
2. Shift the transmission into first gear. The neutral indicator light should go out.
3. Open the throttle gradually, and at the same time, release the clutch lever slowly.

Operation and important riding points

EAU64150

4. At the recommended shift points shown in the following table, close the throttle, and at the same time, quickly pull the clutch lever in.
5. Shift the transmission into second gear. (Make sure not to shift the transmission into the neutral position.)
6. Open the throttle part way and gradually release the clutch lever.
7. Follow the same procedure when shifting to the next higher gear.

TIP

When shifting gears in normal operating conditions, use the recommended shift points.

EAU58270

To decelerate

1. Release the throttle and apply both the front and the rear brakes smoothly to slow the motorcycle.
2. At the recommended shift points shown in the following table, shift to a lower gear.
3. When the motorcycle reaches 25 km/h (16 mph), the engine is about to stall or runs roughly, pull the

clutch lever in, use the brakes to slow the motorcycle, and continue to downshift as necessary.

4. Once the motorcycle has stopped, the transmission can be shifted into the neutral position. The neutral indicator light should come on and then the clutch lever can be released.

EWA17380

WARNING

- **Improper braking can cause loss of control or traction. Always use both brakes and apply them smoothly.**
- **Make sure that the motorcycle and the engine have sufficiently slowed before shifting to a lower gear. Engaging a lower gear when the vehicle or engine speed is too high could make the rear wheel lose traction or the engine to over-rev. This could cause loss of control, an accident and injury. It could also cause engine or drive train damage.**

Recommended shift points

The recommended shift points during acceleration and deceleration are shown in the table below.

Shift up points:

- 1st → 2nd: 20 km/h (12 mph)
- 2nd → 3rd: 30 km/h (19 mph)
- 3rd → 4th: 40 km/h (25 mph)
- 4th → 5th: 50 km/h (31 mph)
- 5th → 6th: 60 km/h (37 mph)

Shift down points:

- 6th → 5th: 45 km/h (28 mph)
- 5th → 4th: 35 km/h (22 mph)
- 4th → 3rd: 25 km/h (16 mph)

Operation and important riding points

EAU17214

Parking

When parking, stop the engine, and then remove the key from the main switch.

EWA10312

WARNING

- Since the engine and exhaust system can become very hot, park in a place where pedestrians or children are not likely to touch them and be burned.
 - Do not park on a slope or on soft ground, otherwise the vehicle may overturn, increasing the risk of a fuel leak and fire.
 - Do not park near grass or other flammable materials which might catch fire.
-

EAU17246

EWA15123

EAU17303

Periodic inspection, adjustment, and lubrication will keep your vehicle in the safest and most efficient condition possible. Safety is an obligation of the vehicle owner/operator. The most important points of vehicle inspection, adjustment, and lubrication are explained on the following pages.

The intervals given in the periodic maintenance charts should be simply considered as a general guide under normal riding conditions. However, depending on the weather, terrain, geographical location, and individual use, the maintenance intervals may need to be shortened.

EWA10322

EWA15461

WARNING

Failure to properly maintain the vehicle or performing maintenance activities incorrectly may increase your risk of injury or death during service or while using the vehicle. If you are not familiar with vehicle service, have a Yamaha dealer perform service.

WARNING

Turn off the engine when performing maintenance unless otherwise specified.

- **A running engine has moving parts that can catch on body parts or clothing and electrical parts that can cause shocks or fires.**
- **Running the engine while servicing can lead to eye injury, burns, fire, or carbon monoxide poisoning – possibly leading to death. See page 2-3 for more information about carbon monoxide.**

WARNING

Brake discs, calipers, drums, and linings can become very hot during use. To avoid possible burns, let brake components cool before touching them.

Emission controls not only function to ensure cleaner air, but are also vital to proper engine operation and maximum performance. In the following periodic maintenance charts, the services related to emissions control are grouped separately. These services require specialized data, knowledge, and equipment. Maintenance, replacement, or repair of the emission control devices and systems may be performed by any repair establishment or individual that is certified (if applicable). Yamaha dealers are trained and equipped to perform these particular services.

Periodic maintenance and adjustment

EAU85230

Tool kit

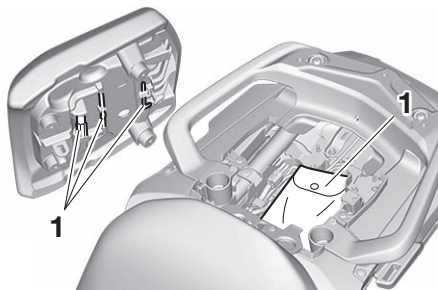

1. Tool kit

The tool kit is in the location shown. The information included in this manual and the tools provided in the tool kit are intended to assist you in the performance of preventive maintenance and minor repairs. However, a torque wrench and other tools are necessary to perform certain maintenance work correctly.

TIP _____

If you do not have the tools or experience required for a particular job, have your Yamaha dealer perform it for you.

Periodic maintenance and adjustment

EAU48491

TIP

- From 24000 mi (37000 km) or 36 months, repeat the maintenance intervals starting from 8000 mi (13000 km) or 12 months.
- Items marked with an asterisk require special tools, data and technical skills, have a Yamaha dealer perform the service.

EAU17602

Periodic maintenance chart for the emission control system

No.	ITEM	ROUTINE	INITIAL	ODOMETER READINGS					
			600 mi (1000 km) or 1 month	4000 mi (7000 km) or 6 months	8000 mi (13000 km) or 12 months	12000 mi (19000 km) or 18 months	16000 mi (25000 km) or 24 months	20000 mi (31000 km) or 30 months	
1	* Fuel line	<ul style="list-style-type: none"> • Check fuel hoses for cracks or damage. • Replace if necessary. 		√	√	√	√	√	√
2	* Spark plugs	<ul style="list-style-type: none"> • Check condition. • Adjust gap and clean. 		√	√	√	√	√	√
		<ul style="list-style-type: none"> • Replace. 	Every 12000 mi (19000 km) or 18 months						
3	* Valve clearance	<ul style="list-style-type: none"> • Check and adjust valve clearance when engine is cold. 	Every 26600 mi (42000 km)						
4	* Crankcase breather system	<ul style="list-style-type: none"> • Check breather hose for cracks or damage. • Replace if necessary. 		√	√	√	√	√	√
5	* Fuel injection	<ul style="list-style-type: none"> • Adjust synchronization. 	√	√	√	√	√	√	√
6	* Exhaust system	<ul style="list-style-type: none"> • Check for leakage. • Tighten if necessary. • Replace gasket(s) if necessary. 	√	√	√	√	√	√	√

Periodic maintenance and adjustment

No.	ITEM	ROUTINE	INITIAL	ODOMETER READINGS					
			600 mi (1000 km) or 1 month	4000 mi (7000 km) or 6 months	8000 mi (13000 km) or 12 months	12000 mi (19000 km) or 18 months	16000 mi (25000 km) or 24 months	20000 mi (31000 km) or 30 months	
7	* Evaporative emission control system (for California only)	<ul style="list-style-type: none"> • Check control system for damage. • Replace if necessary. 				√		√	

Periodic maintenance and adjustment

EAU67552

General maintenance and lubrication chart

No.	ITEM	ROUTINE	INITIAL	ODOMETER READINGS					
			600 mi (1000 km) or 1 month	4000 mi (7000 km) or 6 months	8000 mi (13000 km) or 12 months	12000 mi (19000 km) or 18 months	16000 mi (25000 km) or 24 months	20000 mi (31000 km) or 30 months	
1	* Diagnostic system check	<ul style="list-style-type: none"> Perform dynamic inspection using Yamaha diagnostic tool. Check the error codes. 	√	√	√	√	√	√	
2	* Air filter element	<ul style="list-style-type: none"> Replace. 	Every 24000 mi (37000 km)						
3	* Clutch	<ul style="list-style-type: none"> Check operation. Adjust or replace cable. 	√	√	√	√	√	√	
4	* Front brake	<ul style="list-style-type: none"> Check operation, fluid level, and for fluid leakage. Replace brake pads if necessary. 	√	√	√	√	√	√	
5	* Rear brake	<ul style="list-style-type: none"> Check operation, fluid level, and for fluid leakage. Replace brake pads if necessary. 	√	√	√	√	√	√	
6	* Brake hoses	<ul style="list-style-type: none"> Check for cracks or damage. Check for correct routing and clamping. 		√	√	√	√	√	
		<ul style="list-style-type: none"> Replace. 	Every 4 years						
7	* Brake fluid	<ul style="list-style-type: none"> Change. 	Every 2 years						
8	* Wheels	<ul style="list-style-type: none"> Check runout and for damage. Replace if necessary. 		√	√	√	√	√	
9	* Tires	<ul style="list-style-type: none"> Check tread depth and for damage. Replace if necessary. Check air pressure. Correct if necessary. 		√	√	√	√	√	

Periodic maintenance and adjustment

No.	ITEM	ROUTINE	INITIAL	ODOMETER READINGS				
			600 mi (1000 km) or 1 month	4000 mi (7000 km) or 6 months	8000 mi (13000 km) or 12 months	12000 mi (19000 km) or 18 months	16000 mi (25000 km) or 24 months	20000 mi (31000 km) or 30 months
10	* Wheel bearings	<ul style="list-style-type: none"> • Check bearings for smooth operation. • Replace if necessary. 		√	√	√	√	√
11	* Swingarm pivot bearings	<ul style="list-style-type: none"> • Check operation and for excessive play. 		√	√	√	√	√
		<ul style="list-style-type: none"> • Moderately repack with lithium-soap-based grease. 	Every 32000 mi (50000 km)					
12	Drive chain	<ul style="list-style-type: none"> • Check chain slack, alignment and condition. • Adjust and lubricate chain with a special O-ring chain lubricant thoroughly. 	Every 600 mi (1000 km) and after washing the motorcycle, riding in the rain or riding in wet areas					
13	* Steering bearings	<ul style="list-style-type: none"> • Check bearing assemblies for looseness. 	√	√	√	√	√	√
		<ul style="list-style-type: none"> • Moderately repack with lithium-soap-based grease. 	Every 12000 mi (19000 km)					
14	* Chassis fasteners	<ul style="list-style-type: none"> • Check all chassis fitting and fasteners. • Correct if necessary. 		√	√	√	√	√
15	Brake lever pivot shaft	<ul style="list-style-type: none"> • Apply silicone grease lightly. 		√	√	√	√	√
16	Brake pedal pivot shaft	<ul style="list-style-type: none"> • Apply lithium-soap-based grease lightly. 		√	√	√	√	√
17	Clutch lever pivot shaft	<ul style="list-style-type: none"> • Apply lithium-soap-based grease lightly. 		√	√	√	√	√

Periodic maintenance and adjustment

No.	ITEM	ROUTINE	INITIAL	ODOMETER READINGS					
			600 mi (1000 km) or 1 month	4000 mi (7000 km) or 6 months	8000 mi (13000 km) or 12 months	12000 mi (19000 km) or 18 months	16000 mi (25000 km) or 24 months	20000 mi (31000 km) or 30 months	
18	Shift pedal pivot shaft	<ul style="list-style-type: none"> Apply lithium-soap-based grease lightly. 		√	√	√	√	√	√
19	Sidestand pivot	<ul style="list-style-type: none"> Check operation. Apply molybdenum disulfide grease lightly. 		√	√	√	√	√	√
20	Centerstand pivots	<ul style="list-style-type: none"> Check operation. Apply lithium-soap-based grease lightly. 		√	√	√	√	√	√
21	* Sidestand switch	<ul style="list-style-type: none"> Check operation and replace if necessary. 	√	√	√	√	√	√	√
22	* Front fork	<ul style="list-style-type: none"> Check operation and for oil leakage. Replace if necessary. 		√	√	√	√	√	√
23	* Shock absorber assembly	<ul style="list-style-type: none"> Check operation and for oil leakage. Replace if necessary. 		√	√	√	√	√	√
24	* Rear suspension link pivots	<ul style="list-style-type: none"> Check operation. Correct if necessary. 			√			√	
25	Engine oil	<ul style="list-style-type: none"> Change (warm engine before draining). 	√	√	√	√	√	√	√
26	Engine oil filter cartridge	<ul style="list-style-type: none"> Replace. 	√		√			√	
27	* Cooling system	<ul style="list-style-type: none"> Check coolant level and vehicle for coolant leakage. 		√	√	√	√	√	√
		<ul style="list-style-type: none"> Change coolant. 	Every 3 years						

Periodic maintenance and adjustment

No.	ITEM	ROUTINE	INITIAL	ODOMETER READINGS				
			600 mi (1000 km) or 1 month	4000 mi (7000 km) or 6 months	8000 mi (13000 km) or 12 months	12000 mi (19000 km) or 18 months	16000 mi (25000 km) or 24 months	20000 mi (31000 km) or 30 months
28	* Front and rear brake switches	• Check operation.	√	√	√	√	√	√
29	* Control cables	• Apply Yamaha cable lubricant or other suitable cable lubricant thoroughly.	√	√	√	√	√	√
30	* Throttle grip	• Check operation. • Lubricate throttle grip housing tube guides.		√	√	√	√	√
31	* Lights, signals and switches	• Check operation. • Adjust headlight beam.	√	√	√	√	√	√

EAU17653

8

TIP _____

- Air filter
 - This model uses a disposable oil-coated paper element. This element cannot be cleaned with compressed air, doing so will only damage it.
 - Replace the air filter more frequently if you often ride in the rain or dusty conditions.
- Hydraulic brake service
 - Regularly check the brake fluid levels. Replenish as necessary.
 - Every two years replace the internal components of the brake master cylinders and calipers, and change the brake fluid.
 - Replace the brake hoses every four years or sooner if cracked or damaged.

Periodic maintenance and adjustment

Checking the spark plugs

EAU19653

The spark plugs are important engine components, which should be checked periodically, preferably by a Yamaha dealer. Since heat and deposits will cause any spark plug to slowly erode, they should be removed and checked in accordance with the periodic maintenance and lubrication chart. In addition, the condition of the spark plugs can reveal the condition of the engine.

The porcelain insulator around the center electrode of each spark plug should be a medium-to-light tan (the ideal color when the vehicle is ridden normally), and all spark plugs installed in the engine should have the same color. If any spark plug shows a distinctly different color, the engine could be operating improperly. Do not attempt to diagnose such problems yourself. Instead, have a Yamaha dealer check the vehicle.

If a spark plug shows signs of electrode erosion and excessive carbon or other deposits, it should be replaced.

Specified spark plug:
NGK/LMAR9A-9

Before installing a spark plug, the spark plug gap should be measured with a wire thickness gauge and, if necessary, adjusted to specification.

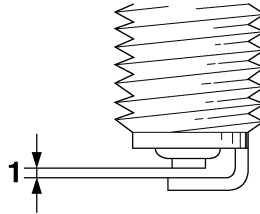

1. Spark plug gap

Spark plug gap:
0.8–0.9 mm (0.031–0.035 in)

Clean the surface of the spark plug gasket and its mating surface, and then wipe off any grime from the spark plug threads.

Tightening torque:
Spark plug:
13 N·m (1.3 kgf·m, 9.6 lb·ft)

TIP

If a torque wrench is not available when installing a spark plug, a good estimate of the correct torque is 1/4–1/2 turn past finger tight. However, the spark plug should be tightened to the specified torque as soon as possible.

ECA10841

NOTICE

Do not use any tools to remove or install the spark plug cap, otherwise the ignition coil coupler may get damaged. The spark plug cap may be difficult to remove because the rubber seal on the end of the cap fits tightly. To remove the spark plug cap, simply twist it back and forth while pulling it out; to install it, twist it back and forth while pushing it in.

Periodic maintenance and adjustment

Canister (for California)

EAU19683

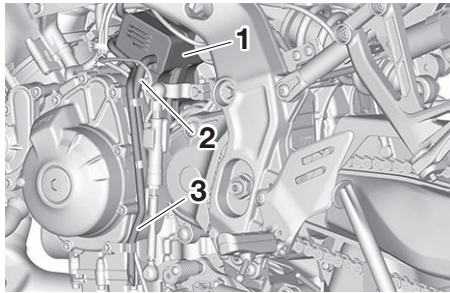

1. Canister
2. Canister breather
3. Fuel tank overflow hose

This model is equipped with a canister to prevent the discharging of fuel vapor into the atmosphere. Before operating this vehicle, make sure to check the following:

- Check each hose connection.
- Check each hose and canister for cracks or damage. Replace if damaged.
- Make sure that the canister breather is not blocked, and if necessary, clean it.

Engine oil

EAU1990G

The engine oil level should be checked regularly. In addition, the oil must be changed and the oil filter cartridge replaced at the intervals specified in the periodic maintenance chart.

Recommended engine oil:

See page 10-1.

Oil quantity:

Oil change:

2.80 L (2.96 US qt, 2.46 Imp.qt)

With oil filter removal:

3.20 L (3.38 US qt, 2.82 Imp.qt)

ECA11621

NOTICE

- **In order to prevent clutch slippage (since the engine oil also lubricates the clutch), do not mix any chemical additives. Do not use oils with a diesel specification of “CD” or oils of a higher quality than specified. In addition, do not use oils labeled “ENERGY CONSERVING II” or higher.**
- **Make sure that no foreign material enters the crankcase.**

To check the engine oil level

1. After warming up the engine, wait a few minutes for the oil level to settle for an accurate reading.
2. With the vehicle on a level surface, hold it upright for an accurate reading.
3. Look at the check window located at the bottom-right side of the crankcase.

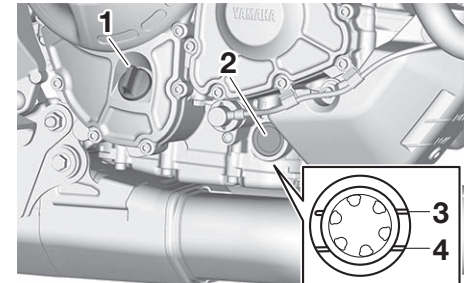

1. Engine oil filler cap
2. Engine oil level check window
3. Maximum level mark
4. Minimum level mark

TIP

The engine oil should be between the minimum and maximum level marks.

Periodic maintenance and adjustment

4. If the engine oil is at or below the minimum level mark, remove the oil filler cap and add oil.
5. Check the engine oil filler cap O-ring. Replace if damaged.

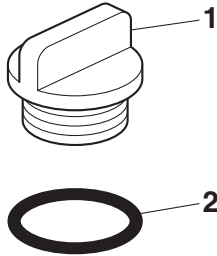

1. Engine oil filler cap
2. O-ring

6. Install the engine oil filler cap.

To change the engine oil (and filter)

1. Start the engine and allow it to idle for a few minutes to warm up the oil, and then stop the engine.
2. Place an oil pan under the engine to collect the used oil.
3. Remove the engine oil filler cap, and then the engine oil drain bolt and gasket.

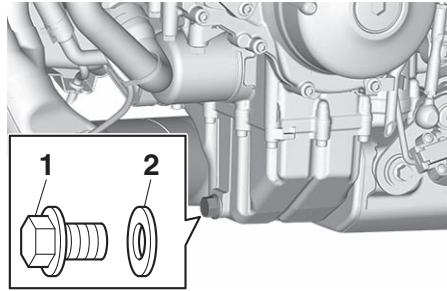

1. Engine oil drain bolt
2. Gasket

TIP

Skip steps 4–6 if the oil filter cartridge is not being replaced.

4. Remove the oil filter cartridge with an oil filter wrench.

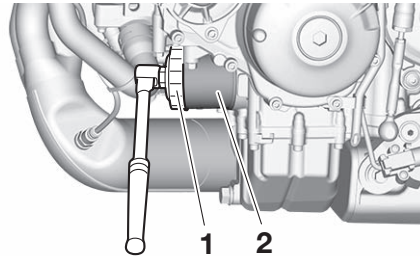

1. Oil filter wrench
2. Oil filter cartridge

TIP

An oil filter wrench is available at a Yamaha dealer.

5. Apply a thin coat of clean engine oil to the O-ring of the new oil filter cartridge.

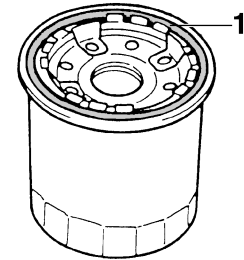

1. O-ring

TIP

Make sure that the O-ring is properly seated.

6. Install the new oil filter cartridge, and then tighten to the specified torque.

Periodic maintenance and adjustment

EAU85450

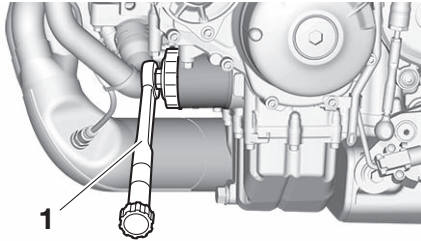

1. Torque wrench

Tightening torque:

Oil filter cartridge:
17 N·m (1.7 kgf·m, 13 lb·ft)

7. Install the engine oil drain bolt with a new gasket, and then tighten the bolt to the specified torque.

Tightening torque:

Engine oil drain bolt:
43 N·m (4.3 kgf·m, 32 lb·ft)

8. Pour the specified amount of the recommended oil into the crankcase.

TIP _____

Using a funnel is recommended.

9. After checking the engine oil filler cap O-ring, install the filler cap.

TIP _____

Wipe off any spilled oil before starting the engine.

10. Start the engine and let it idle while checking for oil leaks.

TIP _____

If any oil leaks are found which you cannot fix, have the vehicle inspected.

11. Stop the engine, wait a few minutes for the oil level to settle, and then check the oil level one last time. **NOTICE: Do not operate the vehicle until you know that the engine oil level is sufficient.**

[ECA10012]

Why Yamalube

YAMALUBE oil is a Genuine YAMAHA Part born of the engineers' passion and belief that engine oil is an important liquid engine component. We form teams of specialists in the fields of mechanical engineering, chemistry, electronics and track testing, and have them develop the engine together with the oil it will use. Yamalube oils take full advantage of the base oil's qualities and blend in the ideal balance of additives to make sure the final oil clears our performance standards. Thus, Yamalube mineral, semisynthetic and synthetic oils have their own distinct characters and value. Yamaha's experience gained over many years of research and development into oil since the 1960's helps make Yamalube the best choice for your Yamaha engine.

YAMALUBE®

Periodic maintenance and adjustment

Coolant

EAUS1203

The coolant level should be checked regularly. In addition, the coolant must be changed at the intervals specified in the periodic maintenance chart.

Recommended coolant:

YAMALUBE coolant

Coolant quantity:

Coolant reservoir (max level mark):
0.28 L (0.30 US qt, 0.25 Imp.qt)

Radiator (including all routes):
1.72 L (1.82 US qt, 1.51 Imp.qt)

TIP

If genuine Yamaha coolant is not available, use an ethylene glycol antifreeze containing corrosion inhibitors for aluminum engines and mix with distilled water at a 1:1 ratio.

EAU20097

To check the coolant level

Since the coolant level varies with engine temperature, check when the engine is cold.

1. Park the vehicle on a level surface.

2. With the vehicle in an upright position, look at the coolant level in the reservoir.

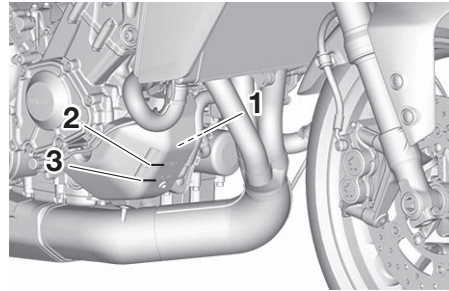

1. Coolant reservoir
2. Maximum level mark
3. Minimum level mark

3. If the coolant is at or below the minimum level mark, remove the coolant reservoir cap. **WARNING! Remove only the coolant reservoir cap. Never attempt to remove the radiator cap when the engine is hot.** [EWA15162]

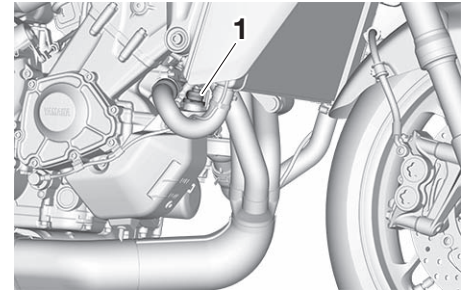

1. Coolant reservoir cap

4. Add coolant to the maximum level mark. **NOTICE: If coolant is not available, use distilled water or soft tap water instead. Do not use hard water or salt water since it is harmful to the engine. If water has been used instead of coolant, replace it with coolant as soon as possible, otherwise the cooling system will not be protected against frost and corrosion. If water has been added to the coolant, have a Yamaha dealer check the anti-freeze content of the coolant as soon as possible, otherwise the effectiveness of the coolant will be reduced.** [ECA10473]

Periodic maintenance and adjustment

5. Install the coolant reservoir cap.

EAU33032

Changing the coolant

The coolant must be changed at the intervals specified in the periodic maintenance and lubrication chart. Have a Yamaha dealer change the coolant.

WARNING! Never attempt to remove the radiator cap when the engine is hot. [EWA10382]

Air filter element

EAU36765

The air filter element must be replaced at the intervals specified in the periodic maintenance and lubrication chart. Have a Yamaha dealer replace the air filter element.

Checking the engine idling speed

EAU44735

Check the engine idling speed and, if necessary, have it corrected by a Yamaha dealer.

Engine idling speed:
1200–1400 r/min

EAU21403

Valve clearance

The valves are an important engine component, and since valve clearance changes with use, they must be checked and adjusted at the intervals specified in the periodic maintenance chart. Unadjusted valves can result in improper air-fuel mixture, engine noise, and eventually engine damage. To prevent this from occurring, have your Yamaha dealer check and adjust the valve clearance at regular intervals.

TIP

This service must be performed when the engine is cold.

EAU64252

Tires

Tires are the only contact between the vehicle and the road. Safety in all conditions of riding depends on a relatively small area of road contact. Therefore, it is essential to maintain the tires in good condition at all times and replace them at the appropriate time with the specified tires.

Tire air pressure

The tire air pressure should be checked and, if necessary, adjusted before each ride.

EWA10504

WARNING

Operation of this vehicle with improper tire pressure may cause severe injury or death from loss of control.

- The tire air pressure must be checked and adjusted on cold tires (i.e., when the temperature of the tires equals the ambient temperature).
- The tire air pressure must be adjusted in accordance with the riding speed and with the total

weight of rider, passenger, cargo, and accessories approved for this model.

Cold tire air pressure:

Up to 90 kg (198 lb) load:

Front:

250 kPa (2.50 kgf/cm², 36 psi)

Rear:

290 kPa (2.90 kgf/cm², 42 psi)

90 kg (198 lb) to maximum load:

Front:

250 kPa (2.50 kgf/cm², 36 psi)

Rear:

290 kPa (2.90 kgf/cm², 42 psi)

Maximum load:

Vehicle:

193 kg (425 lb)

The vehicle's maximum load is the combined weight of the rider, passenger, cargo, and any accessories.

EWA10512

WARNING

Never overload your vehicle. Operation of an overloaded vehicle could cause an accident.

Periodic maintenance and adjustment

Tire inspection

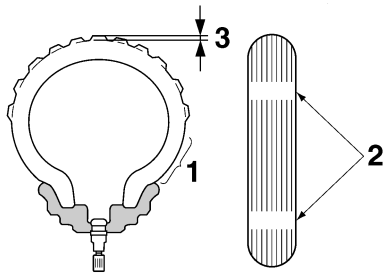

1. Tire sidewall
2. Tire wear indicator
3. Tire tread depth

The tires must be checked before each ride. If a tire tread shows crosswise lines (minimum tread depth), if the tire has a nail or glass fragments in it, or if the sidewall is cracked, contact a Yamaha dealer immediately and have the tire replaced.

Minimum tire tread depth (front and rear):

1.0 mm (0.04 in)

WARNING

EWA10583

- It is dangerous to ride with a worn-out tire. When a tire tread begins to show crosswise lines, have a Yamaha dealer replace the tire immediately.
- The replacement of all wheel and brake-related parts, including the tires, should be left to a Yamaha dealer, who has the necessary professional knowledge and experience to do so.
- Ride at moderate speeds after changing a tire since the tire surface must first be “broken in” for it to develop its optimal characteristics.

Tire information

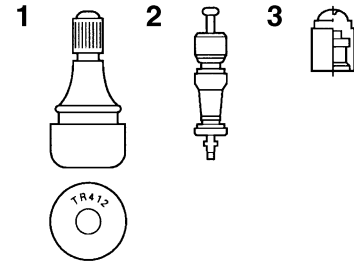

1. Tire air valve
2. Tire air valve core
3. Tire air valve cap with seal

This model is equipped with tubeless tires and tire air valves.

Tires age, even if they have not been used or have only been used occasionally. Cracking of the tread and sidewall rubber, sometimes accompanied by carcass deformation, is an evidence of ageing. Old and aged tires shall be checked by tire specialists to ascertain their suitability for further use.

EWA10902

WARNING

- The front and rear tires should be of the same make and design, otherwise the handling

characteristics of the motorcycle may be different, which could lead to an accident.

- Always make sure that the valve caps are securely installed to prevent air pressure leakage.
- Use only the tire valves and valve cores listed below to avoid tire deflation during a ride.

After extensive tests, only the tires listed below have been approved for this model by Yamaha.

Front tire:

Size:

120/70ZR17M/C (58W)

Manufacturer/model:

BRIDGESTONE/BATTLAX
SPORT TOURING T32F

Rear tire:

Size:

180/55ZR17M/C (73W)

Manufacturer/model:

BRIDGESTONE/BATTLAX
SPORT TOURING T32R

FRONT and REAR:

Tire air valve:

TR412

Valve core:

#9100 (original)

EWA10601

WARNING

This motorcycle is fitted with super-high-speed tires. Note the following points in order to make the most efficient use of these tires.

- Use only the specified replacement tires. Other tires may run the danger of bursting at super high speeds.
- Brand-new tires can have a relatively poor grip on certain road surfaces until they have been “broken in”. Therefore, it is advisable before doing any high-speed riding to ride conservatively for approximately 100 km (60 mi) after installing a new tire.
- The tires must be warmed up before a high-speed run.
- Always adjust the tire air pressure according to the operating conditions.

EAU21963

Cast wheels

To maximize the performance, durability, and safe operation of your vehicle, note the following points regarding the specified wheels.

- The wheel rims should be checked for cracks, bends, warp-age or other damage before each ride. If any damage is found, have a Yamaha dealer replace the wheel. Do not attempt even the smallest repair to the wheel. A deformed or cracked wheel must be replaced.
- The wheel should be balanced whenever either the tire or wheel has been changed or replaced. An unbalanced wheel can result in poor performance, adverse handling characteristics, and a shortened tire life.

Periodic maintenance and adjustment

Adjusting the clutch lever free play

EAU22083

Measure the clutch lever free play as shown.

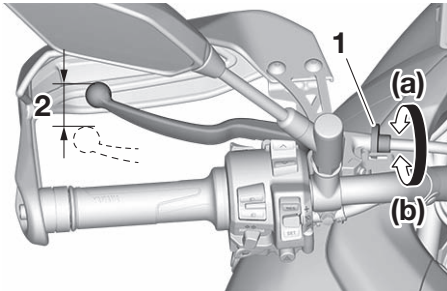

1. Clutch lever free play adjusting bolt
2. Clutch lever free play

Clutch lever free play:
5.0–10.0 mm (0.20–0.39 in)

Periodically check the clutch lever free play and, if necessary, adjust it as follows.

To increase the clutch lever free play, turn the clutch lever free play adjusting bolt in direction (a). To decrease the clutch lever free play, turn the adjusting bolt in direction (b).

TIP _____
If the specified free play cannot be obtained as described above or if the clutch does not operate correctly, have a Yamaha dealer check the internal clutch mechanism.

Checking the brake lever free play

EAU37914

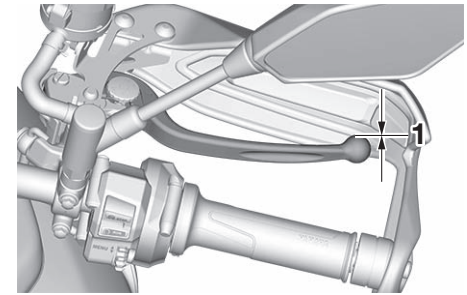

1. No brake lever free play

There should be no free play at the brake lever end. If there is free play, have a Yamaha dealer inspect the brake system.

WARNING

EWA14212

A soft or spongy feeling in the brake lever can indicate the presence of air in the hydraulic system. If there is air in the hydraulic system, have a Yamaha dealer bleed the system before operating the vehicle. Air in the hydraulic system will diminish the

braking performance, which may result in loss of control and an accident.

Brake light switches

EAU36505

The brake light should come on just before braking takes effect. The brake light is activated by switches connected to the brake lever and brake pedal. Since the brake light switches are components of the anti-lock brake system, they should only be serviced by a Yamaha dealer.

Checking the front and rear brake pads

EAU22393

The front and rear brake pads must be checked for wear at the intervals specified in the periodic maintenance and lubrication chart.

Front brake pads

EAU36891

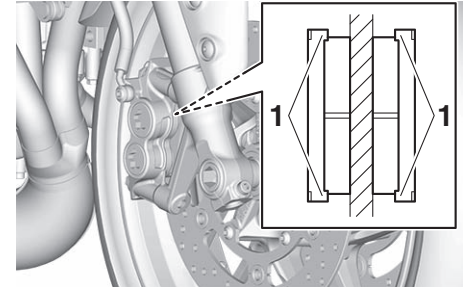

1. Brake pad wear indicator

Each front brake pad is provided with wear indicators, which allows you to check the brake pad wear without having to disassemble the brake. To check the brake pad wear, check the position of the wear indicators while applying the brake. If a brake pad has worn to the point that a wear indicator almost

Periodic maintenance and adjustment

touches the brake disc, have a Yamaha dealer replace the brake pads as a set.

Rear brake pads

EAU46292

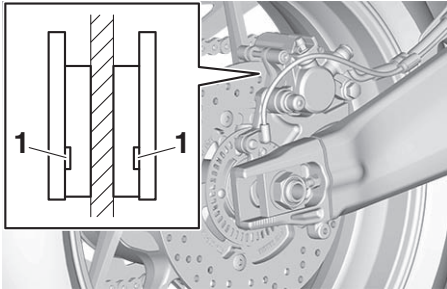

1. Brake pad wear indicator groove

Each rear brake pad is provided with wear indicator grooves, which allow you to check the brake pad wear without having to disassemble the brake. To check the brake pad wear, check the wear indicator grooves. If a brake pad has worn to the point that a wear indicator groove almost appears, have a Yamaha dealer replace the brake pads as a set.

Checking the brake fluid level

EAU40262

Before riding, check that the brake fluid is above the minimum level mark. Check the brake fluid level with the top of the reservoir level. Replenish the brake fluid if necessary.

Front brake

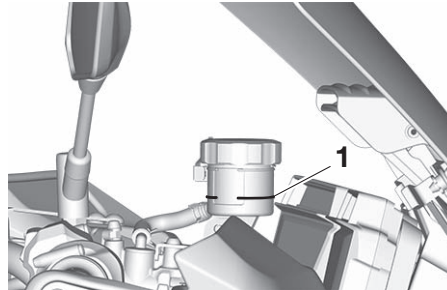

1. Minimum level mark

Rear brake

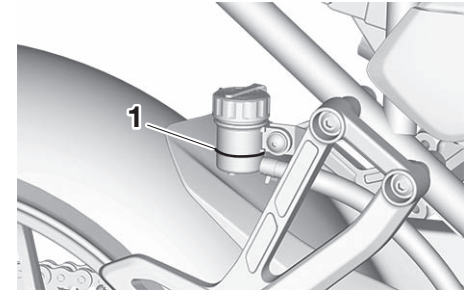

1. Minimum level mark

Specified brake fluid:
DOT 4

EWA16011

! WARNING

Improper maintenance can result in loss of braking ability. Observe these precautions:

- **Insufficient brake fluid may allow air to enter the brake system, reducing braking performance.**
- **Clean the filler cap before removing. Use only DOT 4 brake fluid from a sealed container.**

Periodic maintenance and adjustment

- **Use only the specified brake fluid; otherwise, the rubber seals may deteriorate, causing leakage.**
- **Refill with the same type of brake fluid. Adding a brake fluid other than DOT 4 may result in a harmful chemical reaction.**
- **Be careful that water or dust does not enter the brake fluid reservoir when refilling. Water will significantly lower the boiling point of the fluid and may result in vapor lock, and dirt may clog the ABS hydraulic unit valves.**

ECA17641

NOTICE

Brake fluid may damage painted surfaces or plastic parts. Always clean up spilled fluid immediately.

As the brake pads wear, it is normal for the brake fluid level to gradually go down. A low brake fluid level may indicate worn brake pads and/or brake system leakage; therefore, be sure to check the brake pads for wear and the brake system for leakage. If the brake

fluid level goes down suddenly, have a Yamaha dealer check the cause before further riding.

Changing the brake fluid

EAU22734

Have a Yamaha dealer change the brake fluid every 2 years. In addition, have the seals of the master cylinders and brake calipers, as well as the brake hoses replaced at the intervals listed below or sooner if they are damaged or leaking.

- Brake seals: every 2 years
- Brake hoses: every 4 years

Periodic maintenance and adjustment

Drive chain slack

The drive chain slack should be checked before each ride and adjusted if necessary.

EAU22762

To check the drive chain slack

EAU92611

1. Place the motorcycle on the centerstand.
2. Shift the transmission into the neutral position.
3. Find the center point of the chain (position B) by measuring (approx. 53 mm (2.09 in)) forward from the edge of the drive chain guard as shown.

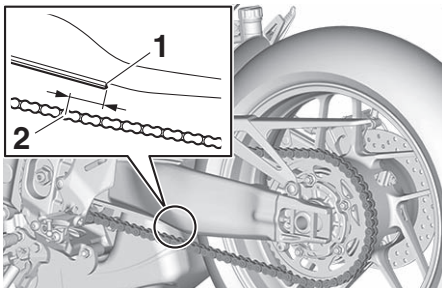

1. Edge of the drive chain guard
2. Position B

4. Push down on the center of the drive chain and measure the distance A from the drive chain guard to the middle of the chain link being pressed down at position B.

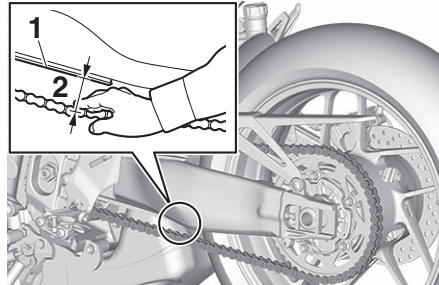

1. Drive chain guard
2. Distance A

Distance A:

45.0–50.0 mm (1.77–1.97 in)

5. If distance A is incorrect, adjust it as follows. **NOTICE: Improper drive chain slack will overload the engine as well as other vital parts of the motorcycle and can lead to chain slippage or breakage. If distance A is more than 55.0 mm (2.17 in), the chain can damage the frame, swingarm,**

and other parts. To prevent this from occurring, keep the drive chain slack within the specified limits. [ECA23070]

EAU92600

To adjust the drive chain slack

Consult a Yamaha dealer before adjusting the drive chain slack.

1. Take the motorcycle off the centerstand, and then put the side-stand down.
2. Loosen the axle nut and the locknut on each side of the swingarm.

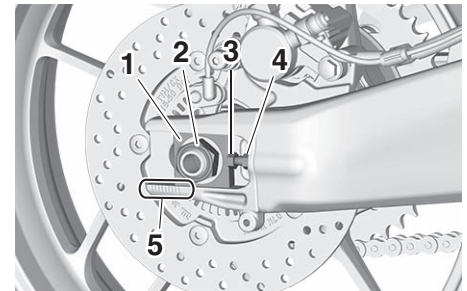

1. Drive chain puller
2. Axle nut
3. Drive chain slack adjusting bolt
4. Locknut
5. Alignment marks

Periodic maintenance and adjustment

- Place the motorcycle on the centerstand.
- To tighten the drive chain, turn the drive chain slack adjusting bolt on each side of the swingarm in direction (a). To loosen the drive chain, turn the adjusting bolt on each side of the swingarm in direction (b), and then push the rear wheel forward.

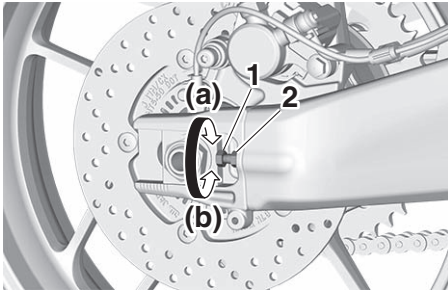

- Drive chain slack adjusting bolt
- Locknut

TIP

Using the alignment marks on each side of the swingarm, make sure that both drive chain pullers are in the same position for proper wheel alignment.

- Take the motorcycle off the centerstand, and then put the sidestand down.
- Tighten the axle nut, then the locknuts to their specified torques.

Tightening torques:

Axle nut:

105 N·m (10.5 kgf·m, 77 lb·ft)

Locknut:

16 N·m (1.6 kgf·m, 12 lb·ft)

- Make sure that the drive chain pullers are in the same position, the drive chain slack is correct, and the drive chain moves smoothly.

Cleaning and lubricating the drive chain

EAU23027

The drive chain must be cleaned and lubricated at the intervals specified in the periodic maintenance and lubrication chart, otherwise it will quickly wear out, especially when riding in dusty or wet areas. Service the drive chain as follows.

ECA10584

NOTICE

The drive chain must be lubricated after washing the motorcycle, riding in the rain or riding in wet areas.

- Clean the drive chain with a drive chain cleaner and a small soft brush. **NOTICE: To prevent damaging the O-rings, do not clean the drive chain with steam cleaners, high-pressure washers or inappropriate solvents.**

[ECA11122]

- Wipe the drive chain dry.
- Thoroughly lubricate the drive chain with a special O-ring chain lubricant. **NOTICE: Do not use engine oil or any other lubri-**

Periodic maintenance and adjustment

cants for the drive chain, as they may contain substances that could damage the O-rings.

[ECA11112]

Checking and lubricating the cables

EAU23098

The operation of all control cables and the condition of the cables should be checked before each ride, and the cables and cable ends should be lubricated if necessary. If a cable is damaged or does not move smoothly, have a Yamaha dealer check or replace it. **WARNING! Damage to the outer housing of cables may result in internal rusting and cause interference with cable movement. Replace damaged cables as soon as possible to prevent unsafe conditions.** [EWA10712]

Recommended lubricant:

Yamaha cable lubricant or other suitable cable lubricant

Checking and lubricating the throttle grip

EAU82490

The operation of the throttle grip should be checked before each ride. In addition, the throttle grip housing should be lubricated by a Yamaha dealer at the intervals specified in the periodic maintenance chart.

Periodic maintenance and adjustment

Checking and lubricating the brake and shift pedals EAU44276

The operation of the brake and shift pedals should be checked before each ride, and the pedal pivots should be lubricated if necessary.

Brake pedal

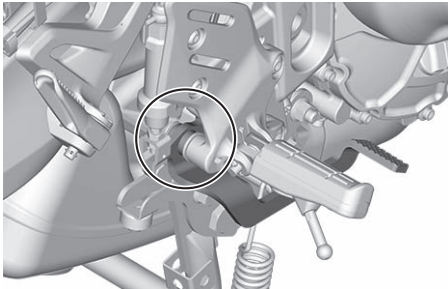

Shift pedal

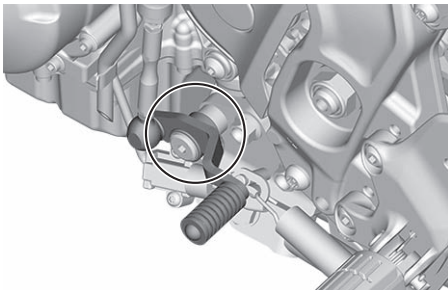

Recommended lubricant:
Lithium-soap-based grease

Checking and lubricating the brake and clutch levers EAU23144

The operation of the brake and clutch levers should be checked before each ride, and the lever pivots should be lubricated if necessary.

Brake lever

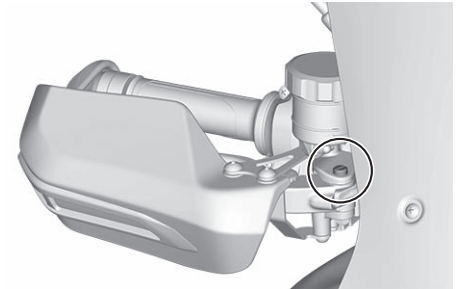

Clutch lever

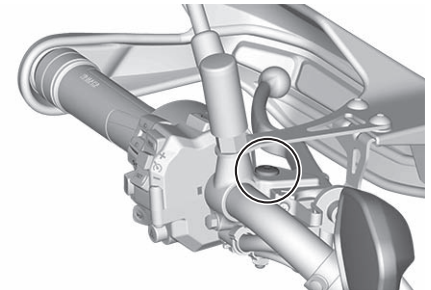

Periodic maintenance and adjustment

Recommended lubricants:

- Brake lever:
 - Silicone grease
- Clutch lever:
 - Lithium-soap-based grease

Checking and lubricating the centerstand and sidestand

EAU88860

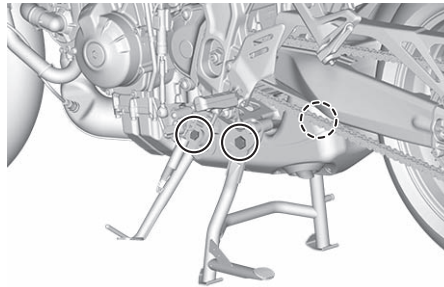

Recommended lubricants:

- Centerstand:
 - Lithium-soap-based grease
- Sidestand:
 - Molybdenum disulfide grease

The operation of the centerstand and sidestand should be checked before each ride, and the pivots and metal-to-metal contact surfaces should be lubricated if necessary.

EWA10742

WARNING

If the centerstand or sidestand does not move up and down smoothly, have a Yamaha dealer check or repair it. Otherwise, the centerstand or sidestand could contact the ground and distract the operator, resulting in a possible loss of control.

Lubricating the swingarm pivots

EAUM1653

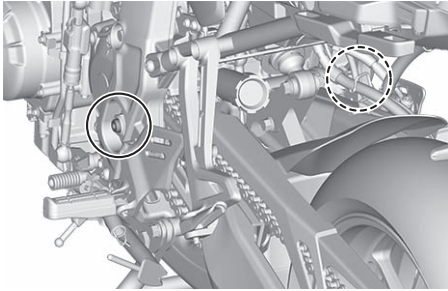

The swingarm pivots must be lubricated by a Yamaha dealer at the intervals specified in the periodic maintenance and lubrication chart.

Recommended lubricant:
Lithium-soap-based grease

Checking the front fork

EAU23273

The condition and operation of the front fork must be checked as follows at the intervals specified in the periodic maintenance and lubrication chart.

To check the condition

Check the inner tubes for scratches, damage and excessive oil leakage.

To check the operation

1. Place the vehicle on a level surface and hold it in an upright position. **WARNING! To avoid injury, securely support the vehicle so there is no danger of it falling over.** [EWA10752]
2. While applying the front brake, push down hard on the handlebars several times to check if the front fork compresses and rebounds smoothly.

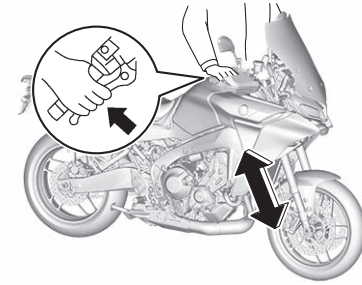

ECA10591

NOTICE

If any damage is found or the front fork does not operate smoothly, have a Yamaha dealer check or repair it.

Periodic maintenance and adjustment

EAU45512

Checking the steering

Worn or loose steering bearings may cause danger. Therefore, the operation of the steering must be checked as follows at the intervals specified in the periodic maintenance and lubrication chart.

1. Place the vehicle on the centerstand. **WARNING! To avoid injury, securely support the vehicle so there is no danger of it falling over.** [EWA10752]
2. Hold the lower ends of the front fork legs and try to move them forward and backward. If any free play can be felt, have a Yamaha dealer check or repair the steering.

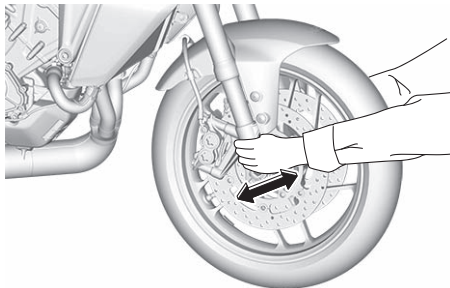

EAU23292

Checking the wheel bearings

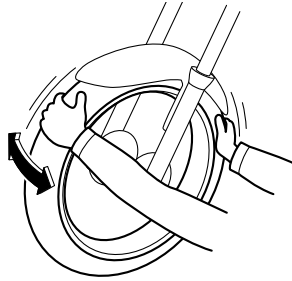

The front and rear wheel bearings must be checked at the intervals specified in the periodic maintenance and lubrication chart. If there is play in the wheel hub or if the wheel does not turn smoothly, have a Yamaha dealer check the wheel bearings.

EAU50212

Battery

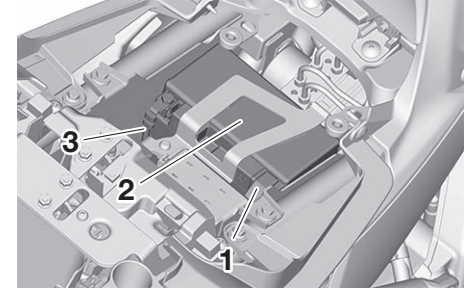

1. Positive battery lead (red)
2. Battery
3. Negative battery lead (black)

The battery is located under the rider seat. (See page 5-26.)

This model is equipped with a VRLA (Valve Regulated Lead Acid) battery. There is no need to check the electrolyte or to add distilled water. However, the battery lead connections need to be checked and, if necessary, tightened.

EWA10761

WARNING

- **Electrolyte is poisonous and dangerous since it contains sulfuric acid, which causes severe**

Periodic maintenance and adjustment

burns. Avoid any contact with skin, eyes or clothing and always shield your eyes when working near batteries. In case of contact, administer the following FIRST AID.

- **EXTERNAL:** Flush with plenty of water.
- **INTERNAL:** Drink large quantities of water or milk and immediately call a physician.
- **EYES:** Flush with water for 15 minutes and seek prompt medical attention.
- **Batteries produce explosive hydrogen gas. Therefore, keep sparks, flames, cigarettes, etc., away from the battery and provide sufficient ventilation when charging it in an enclosed space.**
- **KEEP THIS AND ALL BATTERIES OUT OF THE REACH OF CHILDREN.**

To charge the battery

Have a Yamaha dealer charge the battery as soon as possible if it seems to have discharged. Keep in mind that the

battery tends to discharge more quickly if the vehicle is equipped with optional electrical accessories.

ECA16522

NOTICE

To charge a VRLA (Valve Regulated Lead Acid) battery, a special (constant-voltage) battery charger is required. Using a conventional battery charger will damage the battery.

To store the battery

1. If the vehicle will not be used for more than one month, remove the battery, fully charge it, and then place it in a cool, dry place. **NOTICE: When removing the battery, be sure to turn the main switch off, then disconnect the negative lead before disconnecting the positive lead.** [ECA16304]
2. If the battery will be stored for more than two months, check it at least once a month and fully charge it if necessary.
3. Fully charge the battery before installation. **NOTICE: When installing the battery, be sure to turn the main switch off, then con-**

nect the positive lead before connecting the negative lead.

[ECA16842]

4. After installation, make sure that the battery leads are properly connected to the battery terminals.

ECA16531

NOTICE

Always keep the battery charged. Storing a discharged battery can cause permanent battery damage.

Periodic maintenance and adjustment

EAU92741

Replacing the fuses

The fuse box is located under the rider seat. (See page 5-26.)

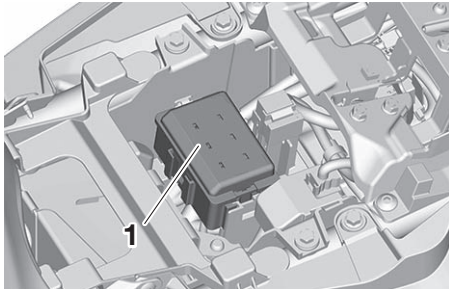

1. Fuse box

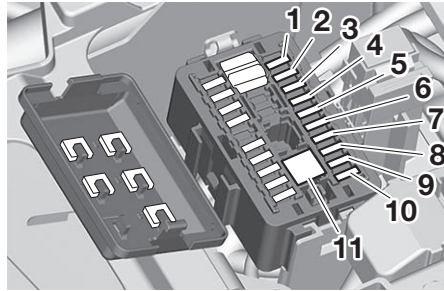

1. Brake light fuse
2. Terminal fuse 2
3. Ignition fuse 2
4. Signaling system fuse
5. Ignition fuse
6. Headlight fuse
7. ABS ECU fuse
8. Fuel injection system fuse
9. Electronic throttle valve fuse
10. Backup fuse 2
11. Main fuse

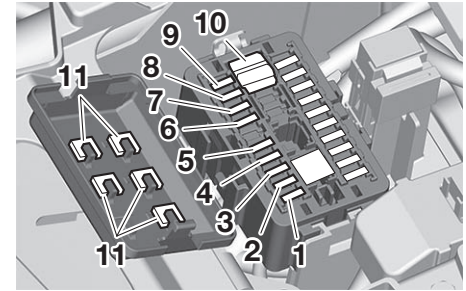

1. ABS motor fuse
2. ABS solenoid fuse
3. Radiator fan motor fuse
4. Accessory fuse 2
5. Terminal fuse 1
6. Backup fuse
7. SCU fuse
8. Heater fuse
9. Cruise control fuse
10. Fuse puller
11. Spare fuse

If a fuse is blown, replace it as follows.

TIP

- There is a spare fuse on the back side of the fuse box cover.
- Use a fuse puller to remove the fuse.

Periodic maintenance and adjustment

1. Turn the main switch off and turn off the electrical circuit in question.
2. Remove the fuse box cover by pressing inwards at the two points indicated on the cover and pulling upwards.

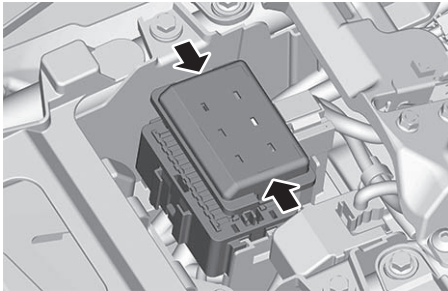

3. Remove the blown fuse using the fuse puller.

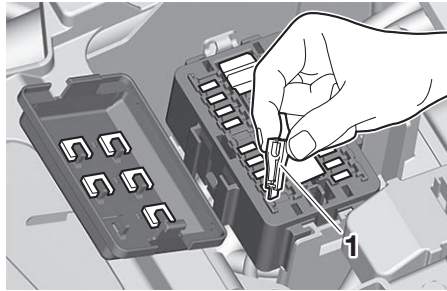

1. Fuse puller

4. Install a new fuse of the specified amperage. **WARNING! Do not use a fuse of a higher amperage rating than recommended to avoid causing extensive damage to the electrical system and possibly a fire.** [EWA15132]

Specified fuses:

- Main fuse:
50.0 A
- Accessory fuse 2:
2.0 A
- Terminal fuse 1:
2.0 A
- Terminal fuse 2:
2.0 A
- Heater fuse:
7.5 A
- Headlight fuse:
7.5 A
- Brake light fuse:
2.0 A
- Signaling system fuse:
7.5 A
- Ignition fuse:
10.0 A
- Ignition fuse 2:
7.5 A
- Radiator fan motor fuse:
15.0 A
- ABS motor fuse:
30.0 A
- ABS ECU fuse:
7.5 A
- SCU fuse:
7.5 A
- Fuel injection system fuse:
7.5 A
- ABS solenoid fuse:
15.0 A

Periodic maintenance and adjustment

Cruise control fuse:
2.0 A
Backup fuse:
7.5 A
Backup fuse 2:
15.0 A
Electronic throttle valve fuse:
7.5 A

5. Insert the fuse puller, and then install the fuse box cover.
6. Turn the main switch on and turn on the electrical circuit in question to check if the device operates.
7. If the fuse immediately blows again, have a Yamaha dealer check the electrical system.

ECA27210

NOTICE

Do not drive while the fuse box cover is removed.

Vehicle lights

EAU80380

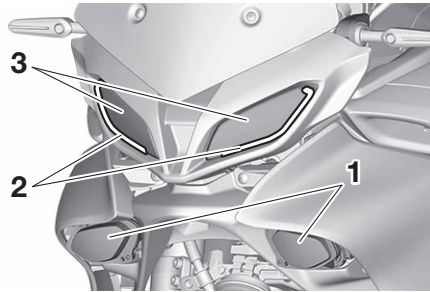

1. Headlight
2. Auxiliary light
3. Cornering light

Except for the license plate light bulb, this model's lights are all LED.

If an LED light does not come on, check the fuses and then have a Yamaha dealer check the vehicle. If the license plate light does not come on, check and replace the bulb. (See page 8-32.)

ECA16581

NOTICE

Do not affix any type of tinted film or stickers to the headlight lens.

Replacing the license plate light bulb

EAU92581

1. Remove the bolts securing the license plate light unit.

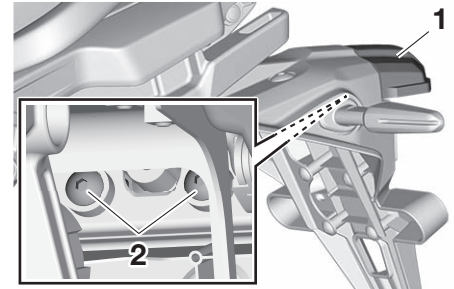

1. License plate light unit
2. Bolt

2. Pull the license plate light unit separate from the rear fender. (Reinstall the collars if they fall out.)

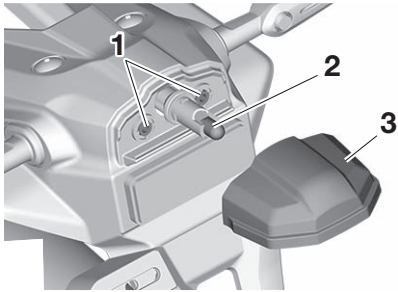

1. Collar
2. License plate light bulb
3. License plate light unit

3. Remove the license plate light bulb socket (together with the bulb) by turning it counterclockwise, and then pulling it out.
4. Remove the burnt-out bulb by pulling it out.
5. Insert a new bulb into the socket.
6. Install the socket (together with the bulb) by pushing it in, and then turning it clockwise until it stops.
7. Install the license plate unit onto the rear fender.
8. Install the bolts and tighten to the specified torque.

Tightening torque:

License plate light unit bolt:
4.0 N·m (0.4 kgf·m, 3.0 lb·ft)

Troubleshooting

Although Yamaha motorcycles receive a thorough inspection before shipment from the factory, trouble may occur during operation. Any problem in the fuel, compression, or ignition systems, for example, can cause poor starting and loss of power.

The following troubleshooting charts represent quick and easy procedures for checking these vital systems yourself. However, should your motorcycle require any repair, take it to a Yamaha dealer, whose skilled technicians have the necessary tools, experience, and know-how to service the motorcycle properly.

Use only genuine Yamaha replacement parts. Imitation parts may look like Yamaha parts, but they are often inferior, have a shorter service life and can lead to expensive repair bills.

WARNING

When checking the fuel system, do not smoke, and make sure there are no open flames or sparks in the area, including pilot lights from water

Periodic maintenance and adjustment

heaters or furnaces. Gasoline or gasoline vapors can ignite or explode, causing severe injury or property damage.

Troubleshooting chart

1. Fuel

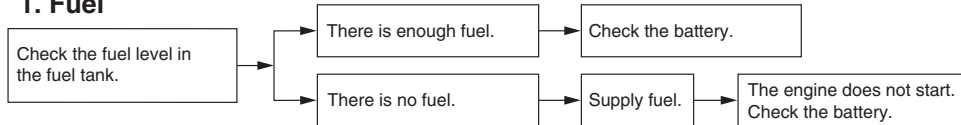

2. Battery

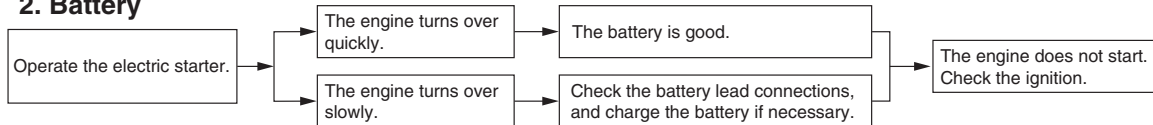

3. Ignition

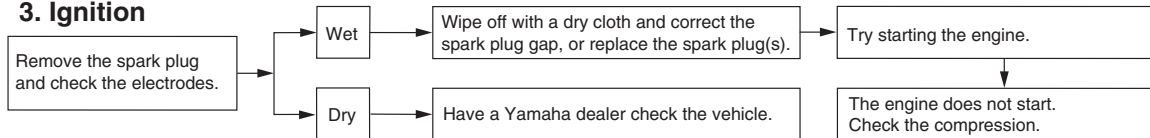

4. Compression

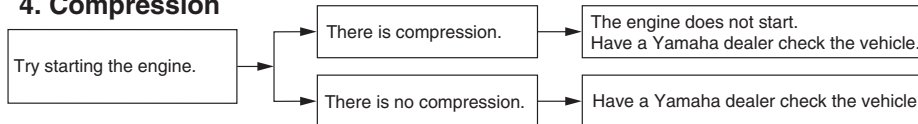

Periodic maintenance and adjustment

EAU86420

Engine overheating

EWAT1041

⚠ WARNING

- Do not remove the radiator cap when the engine and radiator are hot. Scalding hot fluid and steam may be blown out under pressure, which could cause serious injury. Be sure to wait until the engine has cooled.
- Place a thick rag, like a towel, over the radiator cap, and then slowly rotate the cap counterclockwise to the detent to allow any residual pressure to escape. When the hissing sound has stopped, press down on the cap while turning it counterclockwise, and then remove the cap.

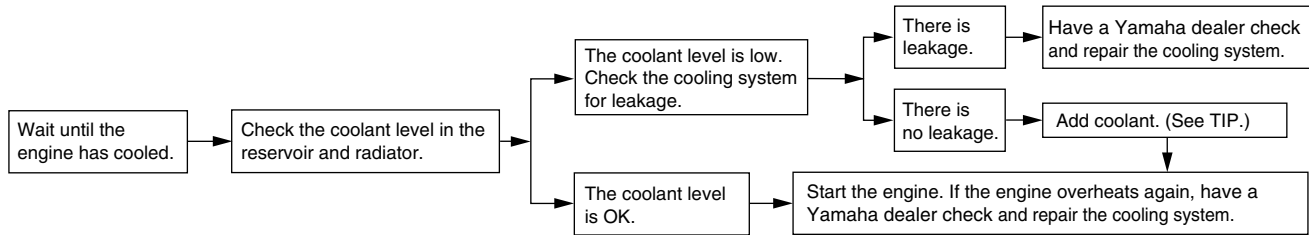

TIP

If coolant is not available, tap water can be temporarily used instead, provided that it is changed to the recommended coolant as soon as possible.

Matte color caution

EAU37834

ECA15193

NOTICE

Some models are equipped with matte colored finished parts. Be sure to consult a Yamaha dealer for advice on what products to use before cleaning the vehicle. Using a brush, harsh chemical products or cleaning compounds when cleaning these parts will scratch or damage their surface. Wax also should not be applied to any matte colored finished parts.

Care

EAU83911

Frequent, thorough cleaning of the vehicle will not only enhance its appearance but also will improve its general performance and extend the useful life of many components. Washing, cleaning, and polishing will also give you a chance to inspect the condition of the vehicle more frequently. Be sure to wash the vehicle after riding in the rain or near the sea, because salt is corrosive to metals.

TIP

- The roads of heavy snowfall areas may be sprayed with salt as a de-icing method. This salt can stay on the roads well into spring, so be sure to wash the underside and chassis parts after riding in such areas.
- Genuine Yamaha care and maintenance products are sold under the YAMALUBE brand.
- See your Yamaha dealer for additional cleaning tips.

ECA26280

NOTICE

Improper cleaning can cause cosmetic and mechanical damage. Do not use:

- high-pressure washers or steam-jet cleaners. Excessive water pressure may cause water seepage and deterioration of wheel bearings, brakes, transmission seals and electrical devices. Avoid high-pressure detergent applications such as those available in coin-operated car washers.
- harsh chemicals, including strong acidic wheel cleaners, especially on spoke or magnesium wheels.
- harsh chemicals, abrasive cleaning compounds, or wax on matte-finished parts. Brushes can scratch and damage the matte-finish, use soft sponge or towel only.
- towels, sponges, or brushes contaminated with abrasive cleaning products or strong

Motorcycle care and storage

chemicals such as, solvents, gasoline, rust removers, brake fluid, or antifreeze, etc.

Before washing

1. Park the vehicle out of direct sunlight and allow it to cool. This will help avoid water spots.
2. Make sure all caps, covers, electrical couplers and connectors are tightly installed.
3. Cover the muffler end with a plastic bag and a strong rubber band.
4. Pre-soak stubborn stains like insects or bird droppings with a wet towel for a few minutes.
5. Remove road grime and oil stains with a biodegradable degreaser (YAMACLEAN Pro-Wash Spray) and a plastic-bristle brush or sponge. **NOTICE: Do not use degreasing agent on areas requiring lubrication such as seals, gaskets, and wheel axles. Follow product instructions.**

[ECA26290]

Washing

1. Rinse off any degreaser and spray down the vehicle with a garden hose. Use only enough pressure to do the job. Avoid spraying water directly into the muffler, instrument panel, air inlet, or other inner areas such as underseat storage compartments.
2. Wash the vehicle with a quality automotive-type detergent (YAMALUBE Wash & Wax) mixed with cool water and a soft, clean towel or sponge. Use an old toothbrush or plastic-bristle brush for hard-to-reach places. **NOTICE: Use cold water if the vehicle has been exposed to salt. Warm water will increase salt's corrosive properties.** [ECA26301]
3. For windshield-equipped vehicles: Clean the windshield with a soft towel or sponge dampened with water and a pH neutral detergent. If necessary, use a high-quality windshield cleaner (YAMACLEAN Glass Cleaner) or windshield polish. **NOTICE: Never use any strong chemicals to clean the**

windshield. Additionally, some cleaning compounds for plastic may scratch the windshield, so be sure to test all cleaning products before general application.

[ECA26310]

4. Rinse off thoroughly with clean water. Be sure to remove all detergent residues, as they can be harmful to plastic parts.

After washing

1. Dry the vehicle with a chamois or absorbent towel, preferably microfiber terrycloth.
2. For drive chain-equipped models, dry and then lubricate it to prevent rust.
3. Use a chrome polish to shine chrome, aluminum, and stainless steel parts. Often the thermally induced discoloring of stainless steel exhaust systems can be removed through polishing.
4. Apply a corrosion protection spray (YAMALUBE Silicone Protectant & Lubricant) on all metal parts including chrome or nickel-plated surfaces. **WARNING! Do not ap-**

ply silicone or oil spray to seats, hand grips, rubber foot pegs or tire treads. Otherwise these parts will become slippery, which could cause loss of control. Thoroughly clean the surfaces of these parts before operating the vehicle. [EWA20650]

5. Treat rubber, vinyl, and unpainted plastic parts with a suitable care product (YAMACLEAN Vinyl Dressing).
6. Touch up minor paint damage caused by stones, etc.
7. Wax all painted surfaces using a non-abrasive wax or use a detail spray for motorcycles (YAMALUBE Spray Polish & Instant Detailer).
8. When finished cleaning, start the engine and let it idle for several minutes to help dry any remaining moisture.
9. If the headlight lens has fogged up, start the engine and turn on the headlight to help remove the moisture.
10. Let the vehicle dry completely before storing or covering it.

ECA26320

NOTICE

- Do not apply wax to rubber or unpainted plastic parts.
- Do not use abrasive polishing compounds as they will wear away the paint.
- Apply sprays and wax sparingly. Wipe off excess afterwards.

EWA20660

⚠ WARNING

Contaminants left on the brakes or tires can cause loss of control.

- Make sure there is no lubricant or wax on the brakes or tires.
- If necessary, wash the tires with warm water and a mild detergent.
- If necessary, clean the brake discs and pads with brake cleaner or acetone.
- Before riding at higher speeds, test the vehicle's braking performance and cornering behavior.

EAU84141

Storage

Always store the vehicle in a cool, dry place. If necessary, protect it against dust with a porous cover. Be sure the engine and the exhaust system are cool before covering the vehicle. If the vehicle often sits for weeks at a time between uses, the use of a quality fuel stabilizer (Fuel Med RX) is recommended after each fill-up.

ECA21170

NOTICE

- Storing the vehicle in a poorly ventilated room or covering it with a tarp, while it is still wet, will allow water and humidity to seep in and cause rust.
- To prevent corrosion, avoid damp cellars, stables (because of the presence of ammonia) and areas where strong chemicals are stored.

Long term storage

Before storing the vehicle long term (60 days or more):

Motorcycle care and storage

1. Make all necessary repairs and perform any outstanding maintenance.
2. Follow all instructions in the Care section of this chapter.
3. Fill up the fuel tank, adding fuel stabilizer according to product instructions. Run the engine for 5 minutes to distribute treated fuel through the fuel system.
4. For vehicles equipped with a fuel cock: Turn the fuel cock lever to the off position.
5. For vehicles with a carburetor: To prevent fuel deposits from building up, drain the fuel in the carburetor float chamber into a clean container. Retighten the drain bolt and pour the fuel back into the fuel tank.
6. Use a quality engine fogging oil (YAMALUBE Stor-Rite Engine Fogging Oil) according to product instructions to protect internal engine components from corrosion. If engine fogging oil is not available, perform the following steps for each cylinder:
 - a. Remove the spark plug cap and spark plug.
 - b. Pour a teaspoonful of engine oil into the spark plug bore.
 - c. Install the spark plug cap onto the spark plug, and then place the spark plug on the cylinder head so that the electrodes are grounded. (This will limit sparking during the next step.)
 - d. Turn the engine over several times with the starter. (This will coat the cylinder wall with oil.)
WARNING! To prevent damage or injury from sparking, make sure to ground the spark plug electrodes while turning the engine over.
[EWA10952]
 - e. Remove the spark plug cap from the spark plug, and then install the spark plug and the spark plug cap.
7. Lubricate all control cables, pivots, levers and pedals, as well as the sidestand and centerstand (if equipped).
8. Check and correct the tire air pressure, and then lift the vehicle so that all wheels are off the ground. Otherwise, turn the wheels a little once a month in order to prevent the tires from becoming degraded in one spot.
9. Cover the muffler outlet with a plastic bag to prevent moisture from entering it.
10. Remove the battery and fully charge it, or attach a maintenance charger to keep the battery optimally charged. **NOTICE: Confirm that the battery and its charger are compatible. Do not charge a VRLA battery with a conventional charger.**[ECA26330]

TIP

- If the battery will be removed, charge it once a month and store it in a temperate location between 32-90 °F (0-30 °C).
 - See page 8-28 for more information on charging and storing the battery.
-

Dimensions:

- Overall length:
2175 mm (85.6 in)
- Overall width:
885 mm (34.8 in)
- Overall height:
1430/1470 mm (56.3/57.9 in)
- Seat height:
810/825 mm (31.9/32.5 in)
- Wheelbase:
1500 mm (59.1 in)
- Ground clearance:
135 mm (5.31 in)
- Minimum turning radius:
3.1 m (10.17 ft)

Weight:

- Curb weight:
220 kg (485 lb)

Engine:

- Combustion cycle:
4-stroke
- Cooling system:
Liquid cooled
- Valve train:
DOHC
- Cylinder arrangement:
Inline
- Number of cylinders:
3-cylinder
- Displacement:
890 cm³
- Bore × stroke:
78.0 × 62.1 mm (3.07 × 2.44 in)

Starting system:

Electric starter

Engine oil:

Recommended brand:



SAE viscosity grades:

10W-40, 10W-50, 15W-40, 20W-40 or
20W-50

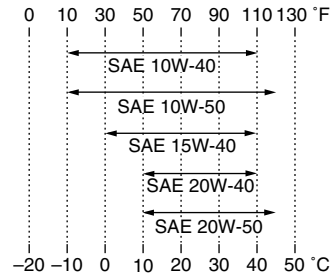

Recommended engine oil grade:

API service SG type or higher, JASO
standard MA

Engine oil quantity:

Oil change:
2.80 L (2.96 US qt, 2.46 Imp.qt)

With oil filter removal:
3.20 L (3.38 US qt, 2.82 Imp.qt)

Coolant quantity:

Coolant reservoir (up to the maximum level
mark):

0.28 L (0.30 US qt, 0.25 Imp.qt)

Radiator (including all routes):

1.72 L (1.82 US qt, 1.51 Imp.qt)

Fuel:

Recommended fuel:

Unleaded gasoline (E10 acceptable)

Octane number (RON):

95

Fuel tank capacity:

19 L (5.0 US gal, 4.2 Imp.gal)

Fuel reserve amount:

3.0 L (0.79 US gal, 0.66 Imp.gal)

Fuel injection:

Throttle body:

ID mark:

B7N1 (MTT9GTMC)

B7N4 (MTT9GTM)

Drivetrain:

Gear ratio:

1st:

2.571 (36/14)

2nd:

1.947 (37/19)

3rd:

1.619 (34/21)

4th:

1.381 (29/21)

5th:

1.190 (25/21)

6th:

1.037 (28/27)

Specifications

Front tire:

Type:

Tubeless

Size:

120/70ZR17M/C (58W)

Manufacturer/model:

BRIDGESTONE/BATTLAX SPORT
TOURING T32F

Rear tire:

Type:

Tubeless

Size:

180/55ZR17M/C (73W)

Manufacturer/model:

BRIDGESTONE/BATTLAX SPORT
TOURING T32R

Loading:

Maximum load:

193 kg (425 lb)

(Total weight of rider, passenger, cargo and accessories)

Front brake:

Type:

Hydraulic dual disc brake

Rear brake:

Type:

Hydraulic single disc brake

Front suspension:

Type:

Telescopic fork

Rear suspension:

Type:

Swingarm (link suspension)

Electrical system:

System voltage:

12 V

Battery:

Model:

YTZ10S

Voltage, capacity:

12 V, 8.6 Ah (10 HR)

Bulb wattage:

Headlight:

LED

Brake/tail light:

LED

Front turn signal/position light:

LED

Rear turn signal light:

LED

Auxiliary light:

LED

License plate light:

5.0 W

Identification numbers

EAU26357

Record the vehicle identification number, engine serial number, model label information, and the key identification number in the spaces provided below. These identification numbers are needed when registering the vehicle with the authorities in your area and when ordering spare parts from a Yamaha dealer.

VEHICLE IDENTIFICATION NUMBER:

ENGINE SERIAL NUMBER:

MODEL LABEL INFORMATION:

KEY IDENTIFICATION NUMBER:

Vehicle identification number

EAU26401

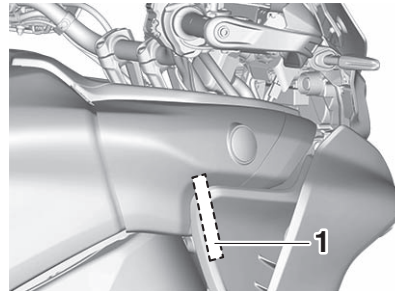

1. Vehicle identification number

The vehicle identification number is stamped into the steering head pipe. Record this number in the space provided.

TIP

The vehicle identification number is used to identify your motorcycle and may be used to register your motorcycle with the licensing authority in your area.

Engine serial number

EAU26442

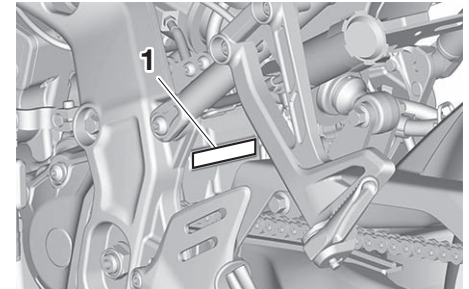

1. Engine serial number

The engine serial number is stamped into the crankcase.

Consumer information

Model label

EAU26471

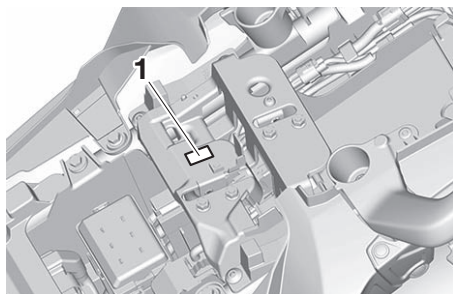

1. Model label

The model label is affixed to the frame under the rider seat. (See page 5-26.) Record the information on this label in the space provided. This information will be needed when ordering spare parts from a Yamaha dealer.

Key identification number

EAU26382

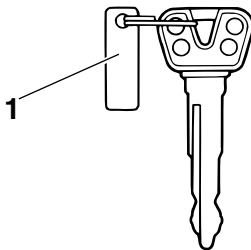

1. Key identification number

The key identification number is stamped into the key tag. Record this number in the space provided and use it for reference when ordering a new key.

Vehicle Emission Control Information label

EAU48271

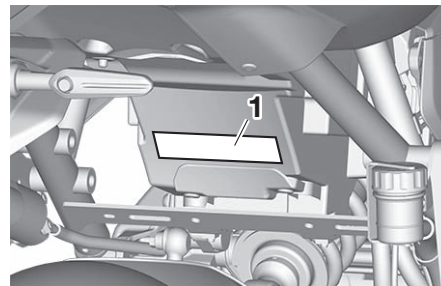

1. Vehicle Emission Control Information label

The Vehicle Emission Control Information label is affixed at the location in the illustration. This label shows specifications related to exhaust emissions as required by federal law, state law and Environment Canada.

Diagnostic connector

EAU69910

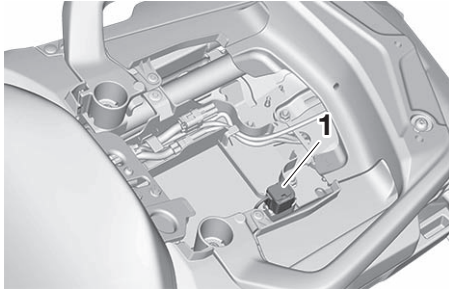

1. Diagnostic connector

The diagnostic connector is located as shown.

Vehicle data recording

EAU90250

This model's ECU stores certain vehicle data to assist in the diagnosis of malfunctions and for research, statistical analysis and development purposes.

Although the sensors and recorded data will vary by model, the main data points are:

- Vehicle status and engine performance data
- Fuel-injection and emission-related data

This data will be uploaded only when a special Yamaha diagnostic tool is attached to the vehicle, such as when maintenance checks or service procedures are performed.

Vehicle data uploaded will be handled appropriately according to the following Privacy Policy.

Privacy Policy

<https://yamaha-motor.com/privacy-policy>

Yamaha will not disclose this data to a third party except in the following cases. In addition, Yamaha may provide vehicle data to a contractor in order to outsource services related to the handling of vehicle data. Even in this case, Yamaha will require the contractor to properly handle the vehicle data we provided and Yamaha will appropriately manage the data.

- With the consent of the vehicle owner
- Where obligated by law
- For use by Yamaha in litigation
- When the data is not related to an individual vehicle nor owner

Consumer information

EAU26553

Reporting safety defects

If you believe that your vehicle has a defect which could cause a crash or could cause injury or death, you should immediately inform the National Highway Traffic Safety Administration (NHTSA) in addition to notifying Yamaha Motor Corporation, U.S.A. If NHTSA receives similar complaints, it may open an investigation, and if it finds that a safety defect exists in a group of vehicles, it may order a recall and remedy campaign. However, NHTSA cannot become involved in individual problems between you, your dealer, or Yamaha Motor Corporation, U.S.A.

To contact NHTSA, you may call the Vehicle Safety Hotline toll-free at 1-888-327-4236 (TTY: 1-800-424-9153); go to <http://www.safercar.gov>; or write to: Administrator, NHTSA, 1200 New Jersey Avenue, SE, West Building, Washington, DC 20590. You can also obtain other information about motor vehicle safety from <http://www.safercar.gov>.

Motorcycle noise regulation

TAMPERING WITH NOISE CONTROL SYSTEM PROHIBITED:

Federal law prohibits the following acts or the causing thereof: (1) The removal or rendering inoperative by any person other than for purposes of maintenance, repair, or replacement of any device or element of design incorporated into any new vehicle for the purpose of noise control prior to its sale or delivery to the ultimate purchaser or while it is in use or (2) the use of the vehicle after such device or element of design has been removed or rendered inoperative by any person. “AMONG THOSE ACTS PRESUMED TO CONSTITUTE TAMPERING ARE THE ACTS LISTED BELOW”.

These acts include tampering with the following systems; i.e., modification, removal, etc.

Exhaust system

- Muffler
- Exhaust pipe
- Silencer

Intake system

- Air cleaner case
- Air cleaner element
- Intake duct

Consumer information

EAU26633

Maintenance record

Copies of work orders and/or receipts for parts purchased and installed on your vehicle will be required to document that maintenance has been completed in accordance with the emissions warranty. The chart below is printed only as a reminder that maintenance work is required. It is not acceptable proof of maintenance work.

Maintenance interval	Date of service	Mileage	Servicing dealer name and address	Remarks
600 mi (1000 km) or 1 month				
4000 mi (7000 km) or 6 months				
8000 mi (13000 km) or 12 months				
12000 mi (19000 km) or 18 months				
16000 mi (25000 km) or 24 months				
20000 mi (31000 km) or 30 months				
24000 mi (37000 km) or 36 months				
28000 mi (43000 km) or 42 months				
32000 mi (49000 km) or 48 months				

Consumer information

Maintenance interval	Date of service	Mileage	Servicing dealer name and address	Remarks
36000 mi (55000 km) or 54 months				
40000 mi (61000 km) or 60 months				

Consumer information

EAU61803

YAMAHA MOTOR CORPORATION, U.S.A. 2020 AND LATER MODEL STREET & DUAL-PURPOSE MOTORCYCLE LIMITED WARRANTY

Yamaha Motor Corporation, U.S.A. hereby warrants that each new Yamaha motorcycle purchased from an authorized Yamaha motorcycle dealer in the continental United States will be free from defects in material and workmanship for the period of time stated herein, subject to certain stated limitations.

THE PERIOD OF WARRANTY for Yamaha motorcycles originally equipped with headlight, stoplight, and turn signals shall be one (1) year from the date of purchase, with no mileage limitation, except for the battery, which is warranted for thirty (30) days from the date of purchase.

DURING THE PERIOD OF WARRANTY any authorized Yamaha motorcycle dealer will, free of charge, repair or replace, at Yamaha's option, any part adjudged defective by Yamaha due to faulty workmanship or material from the factory. Parts used in warranty repairs will be warranted for the balance of the product's warranty period. All parts replaced under warranty become the property of Yamaha Motor Corporation, U.S.A.

GENERAL EXCLUSIONS from this warranty shall include any failures caused by:

- Competition or racing use.
- Installation of parts or accessories that are not qualitatively equivalent to genuine Yamaha parts.
- Abnormal strain, neglect, or abuse.
- Lack of proper maintenance and off-season storage as described in the Owner's Manual.
- Accident or collision damage.
- Modification to original parts.
- Damage due to improper transportation

SPECIFIC EXCLUSIONS from this warranty shall include parts replaced due to normal wear or routine maintenance.

THE CUSTOMER'S RESPONSIBILITY under this warranty shall be to:

- Operate and maintain the motorcycle as specified in the appropriate Owner's Manual, and

- Give notice to an authorized Yamaha motorcycle dealer of any and all apparent defects within ten (10) days after discovery, and make the machine available at that time for inspection and repairs at such dealer's place of business.

WARRANTY TRANSFER: To transfer the warranty from the original purchaser to any subsequent purchaser, it is imperative that the machine be inspected and registered for warranty by an authorized Yamaha motorcycle dealer. In order for this warranty to remain in effect, this inspection and registration must take place within ten (10) days after transfer. A reasonable dealer-imposed fee may be charged for the inspection.

EMISSIONS CONTROL SYSTEM WARRANTY

Yamaha Motor Corporation, U.S.A. also warrants to the ultimate purchaser and each subsequent purchaser of each Yamaha motorcycle covered by this warranty that the vehicle is designed, built, and equipped so as to conform at the time of sale with all U.S. emissions standards applicable at the time of manufacture and that it is free from defects in materials and workmanship which would cause it not to meet these standards within the periods listed immediately below. Failures other than those resulting from defects in material or workmanship which arise solely as a result of owner abuse and/or lack of proper maintenance are not covered by this warranty.

ENGINE DISPLACEMENT

ENGINE DISPLACEMENT	PERIOD
Under 50cc	6,000 km (3,750 miles) or five years, whichever occurs first
50cc to 169cc	12,000 km (7,465 miles) or five years, whichever occurs first
170cc to 279cc	18,000 km (11,185 miles) or five years, whichever occurs first
280cc or over	30,000 km (18,641 miles) or five years, whichever occurs first

YAMAHA MOTOR CORPORATION, U.S.A. MAKES NO OTHER WARRANTY OF ANY KIND, EXPRESSED OR IMPLIED. ALL IMPLIED WARRANTIES OF MERCHANTABILITY AND FITNESS FOR A PARTICULAR PURPOSE WHICH EXCEED THE OBLIGATIONS AND TIME LIMITS STATED IN THIS WARRANTY ARE HEREBY DISCLAIMED BY YAMAHA MOTOR CORPORATION, U.S.A. AND EXCLUDED FROM THIS WARRANTY.

SOME STATES DO NOT ALLOW LIMITATIONS ON HOW LONG AN IMPLIED WARRANTY LASTS, SO THE ABOVE LIMITATIONS MAY NOT APPLY TO YOU. ALSO EXCLUDED FROM THIS WARRANTY ARE ANY INCIDENTAL OR CONSEQUENTIAL DAMAGES INCLUDING LOSS OF USE. SOME STATES DO NOT ALLOW THE EXCLUSION OR LIMITATION OF INCIDENTAL OR CONSEQUENTIAL DAMAGES, SO THE ABOVE EXCLUSION MAY NOT APPLY TO YOU.

THIS WARRANTY GIVES YOU SPECIFIC LEGAL RIGHTS, AND YOU MAY ALSO HAVE OTHER RIGHTS WHICH VARY FROM STATE TO STATE.

YAMAHA MOTOR CORPORATION, U.S.A.
Post Office Box 6555
Cypress, California 90630
1-800-962-7926

WARRANTY QUESTIONS AND ANSWERS

- Q. What costs are my responsibility during the warranty period?
- A. The customer's responsibility includes all costs of normal maintenance services, non-warranty repairs, accident and collision damages, and oil, oil filters, air filters, spark plugs, and brake shoes.
- Q. What are some examples of "abnormal" strain, neglect, or abuse?
- A. These terms are general and overlap each other in areas. Specific examples include: Running the machine out of oil, sustained high rpm, full-throttle, operating the machine with a broken or damaged part which causes another part to fail, damage or failure due to improper or careless transportation and/or tie-down. If you have any specific questions on operation or maintenance, please contact your dealer for advice.
- Q. Does the warranty cover incidental costs such as towing or transportation due to a failure?
- A. No. The warranty is limited to repair of the machine itself.
- Q. May I perform any or all of the recommended maintenance shown in the Owner's Manual instead of having the dealer do them?
- A. Yes, if you are a qualified mechanic and follow the procedures specified in the Owner's and Service Manual. We do recommend, however, that items requiring special tools or equipment be done by a Yamaha motorcycle dealer.
- Q. Will the warranty be void or cancelled if I do not operate or maintain my new motorcycle exactly as specified in the Owner's Manual?
- A. No. The warranty on a new motorcycle cannot be "voided" or "cancelled." **However, if a particular failure is caused by operation or maintenance other than as described in the Owner's Manual, that failure may not be covered under warranty.**
- Q. What responsibility does my dealer have under this warranty?
- A. Each Yamaha motorcycle dealer is expected to:
1. Completely set up every new machine before sale.
 2. Explain the operation, maintenance, and warranty requirements to your satisfaction at the time of sale, and upon your request at any later date.
 3. Each Yamaha motorcycle dealer is held responsible for his setup, service and warranty repair work.
- Q. Is the warranty transferable to second owners?
- A. Yes. The remainder of the existing warranty can be transferred upon request. The unit has to be inspected and re-registered by an authorized Yamaha motorcycle dealer for the policy to remain effective.

CUSTOMER SERVICE

If your machine requires warranty service, you must take it to any authorized Yamaha motorcycle dealer within the continental United States. Be sure to bring your warranty registration card or other valid proof of the original date of purchase. If a question or problem arises regarding the warranty, first contact the owner of the dealership. Since all warranty matters are handled at the dealer level, this person is in the best position to help you. If you are still not satisfied and require additional assistance, please write to:

YAMAHA MOTOR CORPORATION, U.S.A.
CUSTOMER RELATIONS DEPARTMENT
P.O. Box 6555
Cypress, California 90630

When contacting Yamaha Motor Corporation, U.S.A., don't forget to include any important information such as names, addresses, model, VIN (vehicle identification number), dates, and receipts.

CHANGE OF ADDRESS

The federal government requires each manufacturer of a motor vehicle to maintain a complete, up-to-date list of all first purchasers against the possibility of a safety-related defect and recall. This list is compiled from the purchase registrations sent to Yamaha Motor Corporation, U.S.A. by the selling dealer at the time of your purchase.

If you should move after you have purchased your new motorcycle, please advise us of your new address by sending a postcard listing your motorcycle model name, VIN number, dealer number (or dealer's name) as it is shown on your warranty card, your name and new mailing address. Mail to:

YAMAHA MOTOR CORPORATION, U.S.A.
1270 Chastain Road
Kennesaw, GA 30144
Attention: Warranty Department

This will ensure that Yamaha Motor Corporation, U.S.A. has an up-to-date registration record in accordance with federal law.

YAMAHA EXTENDED SERVICE (Y.E.S.)

Keep your Yamaha protected even after your limited warranty expires with genuine Yamaha Extended Service (Y.E.S.).

- Y.E.S. is designed and administered by Yamaha Motor Corporation to provide maximum owner satisfaction. It provides uninterrupted factory-backed coverage for extra peace of mind.
- Y.E.S. is flexible. You choose the plan that's right for you: 12 months, 24 months, 36 months or, on certain models, even 48 months beyond your warranty period.
- Y.E.S. is designed and administered by the same Yamaha people who handle your warranty – and it shows in the comprehensive coverage benefits. There are no mileage limitations. Coverage isn't limited to "moving parts" or the "drivetrain" like many other plans. And Y.E.S. covers manufacturing defects just like the warranty. See the sample contract at your Yamaha dealer to see how comforting uninterrupted factory-backed protection can be.
- You don't have to pay anything for covered repairs. There's no deductible to pay, and repairs aren't "pro-rated." You don't have any "out-of-pocket" expenses for covered repairs.
- In addition, Travel and Recreation Interruption Protection (TRIP) is included at no extra cost. TRIP gives you up to \$250 reimbursement per occurrence for any reasonable expenses you incur because your Yamaha needs covered service: replacement vehicle rental, emergency towing, phone calls, even food and lodging when you are away from home. This superb coverage goes into effect when you purchase Y.E.S., so it applies to any warranty repairs as well as covered repairs during your entire Y.E.S. plan period.
- Y.E.S. coverage is honored at any authorized Yamaha dealer nationwide.
- Y.E.S. coverage is transferable to a new owner if you sell or trade-in. That can make your Yamaha much more valuable!

This excellent Y.E.S. plan coverage is only available to Yamaha owners like you, and only while your Yamaha is still within the Yamaha Limited Warranty period. So visit your authorized Yamaha dealer to get all the facts. They can show you how easy it is to protect your investment with Yamaha Extended Service.

We urge you to act now. You'll get the excellent benefits of TRIP coverage right away, and you'll rest easy knowing you'll have strong factory-backed protection even after your Yamaha Limited Warranty expires.

A special note:

If visiting your dealer isn't convenient, contact Yamaha with your VIN number and we'll be happy to help you get the Y.E.S. coverage you need.

Yamaha Service Marketing

P.O. Box 6555

Cypress, CA 90630

1-(866)-YES-EXTD (1-866-937-3983)



YAMAHA



EXTENDED



SERVICE

Index

- A**
ABS warning light5-6
Air filter element8-14
Auxiliary DC connector5-33
Auxiliary DC jack5-33
Auxiliary system warning light5-7
- B**
Battery8-28
BC4-7
Brake and clutch levers, checking and lubricating8-25
Brake and shift pedals, checking and lubricating8-25
Brake control system (BC)5-21
Brake fluid, changing8-21
Brake fluid level, checking8-20
Brake lever5-21
Brake lever free play, checking8-18
Brake light switches8-19
Brake pedal5-21
- C**
Cables, checking and lubricating8-24
Canister (for California)8-10
Care9-1
Catalytic converter5-26
Centerstand and sidestand, checking and lubricating8-26
Clutch lever5-20
Clutch lever free play, adjusting8-18
Coolant8-13
Cruise control indicator lights5-5
Cruise control switches5-3
Cruise control system4-1
- D**
Data recording, vehicle11-3
Diagnostic connector11-3
Dimmer/Pass switch5-2
Display, menu screen5-15
Displays5-7
D-MODE4-3
Drive chain, cleaning and lubricating ... 8-23
Drive chain slack8-22
- E**
Engine break-in7-1
Engine idling speed, checking8-14
Engine oil8-10
Engine overheating8-36
Engine serial number11-1
Engine trouble warning light5-6
- F**
Front and rear brake pads, checking ... 8-19
Front fork, checking8-27
Fuel5-23
Fuel level warning light5-5
Fuel tank breather hose and overflow hose5-25
Fuel tank cap5-23
Fuses, replacing8-30
- H**
Handlebar position, adjusting5-31
Handlebar switches5-2
Hazard switch5-3
High beam indicator light5-5
Horn switch5-3
- I**
Identification numbers11-1
Ignition circuit cut-off system5-34
- Indicator lights and warning lights5-5
- K**
Key identification number11-2
- L**
Labels, location1-1
License plate light bulb, replacing8-32
Luggage strap holders5-32
- M**
Main switch/steering lock5-1
Maintenance and lubrication, periodic...8-5
Maintenance, emission control system8-3
Maintenance record11-6
Matte color, caution9-1
Model label11-2
- N**
Neutral indicator light5-5
Noise regulation11-5
- O**
Oil pressure and Coolant temperature warning light5-6
- P**
Parking7-5
Part locations3-1
- Q**
QSS4-6
- R**
Rider footrest position, adjusting5-30
Rider seat height, adjusting5-27
- S**
Safety defects, reporting11-4
Safety information2-1
Seats5-26
Shifting7-3

Shift pedal	5-20	Wheel bearings, checking.....	8-28
Sidestand	5-34	Wheels	8-17
Spark plugs, checking.....	8-9	Windshield.....	5-30
Special features.....	4-1	Y	
Specifications	10-1	Yamalube	8-12
Stability control indicator light.....	5-6		
Starting the engine	7-2		
Steering, checking.....	8-28		
Stop/Run/Start switch.....	5-3		
Storage.....	9-3		
Storage compartment	5-30		
SUS-MODE	4-4		
Suspension, adjusting the front and rear	5-31		
Swingarm pivots, lubricating.....	8-27		
T			
TCS-MODE.....	4-5		
Throttle grip, checking and lubricating.....	8-24		
Tires.....	8-15		
Tool kit.....	8-2		
Troubleshooting.....	8-33		
Troubleshooting chart	8-35		
Turn signal indicator lights	5-5		
Turn signal switch.....	5-3		
V			
Valve clearance	8-15		
Vehicle Emission Control Information label.....	11-2		
Vehicle identification number	11-1		
Vehicle lights	8-32		
W			
Warranty, extended.....	11-10		
Warranty, limited	11-8		

For your best ownership experience, think **Genuine Yamaha!**

Genuine Yamaha Parts – Genuine Yamaha replacement parts are the exact same parts as the ones originally equipped on your vehicle, providing you with the performance and durability you have come to expect. Why settle for aftermarket parts that may not provide full confidence and satisfaction?

Genuine Yamaha Accessories – Yamaha only offers accessories that meet our high standards for quality and performance. Buy with confidence, knowing your Genuine Yamaha Accessories will fit right and perform right – right out of the box.

Yamalube – Take care of your Yamaha with legendary Yamalube oils, lubricants, and care products. They're formulated and approved by the toughest judges we know: the Yamaha engineering teams that know your Yamaha from the inside out.

Genuine Yamaha Service Manuals – Get the same factory manual for your vehicle that the technicians at your authorized Yamaha dealer use. Service manuals are available through your Yamaha dealer or you can order them directly through yamahapubs.com (for US consumers only).

Genuine Yamaha products are available only from your Yamaha dealer.

Find out more at:

For US consumers, please visit yamaha-motor.com

For Canadian consumers, please visit yamaha-motor.ca



PRINTED IN JAPAN
2021.02-0.5×1 CR (E)